

09/06/85 Midwest Express Airlines, Inc.

Official Accident Report Index Page

Report Number	NTSB/AAR-87/01
Access Number	PB87-910401
Report Title	Midwest Express Airlines, Inc. DC-9-14, N100 ME, General Billy Mitchell Field, Milwaukee, Wisconsin, September 6, 1985
Report Date	February 3, 1987
Organization Name	National Transportation Safety Board Bureau of Accident Investigation Washington, D.C. 20594
WUN	4267-A
Sponsor Name	NATIONAL TRANSPORTATION SAFETY BOARD Washington, D. C. 20594
Report Type	Aircraft Accident Report September 6, 1985
Distribution Status	This document is available through the National Technical Information Service, Springfield, Virginia, 22161
Report Class	UNCLASSIFIED
Pg Class	UNCLASSIFIED
Pages	105
Keywords	removable sleeve spacer; high pressure compressor spacer; improper use of flight controls

Abstract

At 1521 c.d.t. on September 6, 1985, Midwest Express Airlines, Inc., Flight 105, a McDonnell-Douglas DC-9-14 airplane, crashed into an open field at the edge of a wooded area about 1,680 feet southwest of the departure end of runway 19R shortly after taking off from General Billy Mitchell Field, Milwaukee, Wisconsin. The weather was clear with visibility 10 miles. During the initial climb, about 450 feet above ground level (a.g.l.), there was a loud noise and a loss of power associated with an uncontained failure of the 9th to 10th stage high pressure compressor spacer of the right engine. Flight 105 continued to climb to about 700 feet a.g.l. and then rolled to the right until the wings were observed in a near vertical, approximately right 90° banked turn. During the roll, the airplane entered an accelerated stall, control was lost, and the airplane crashed. The aircraft was destroyed by impact forces and postcrash fire. The pilot, the first officer, both flight attendants, and all 27 passengers were fatally injured.

The National Transportation Safety Board determines that the probable cause of this accident was the flightcrew's improper use of flight controls in response to the catastrophic failure of the right engine during a critical phase of flight, which led to an accelerated stall and loss of control of the airplane. Contributing to the loss of control was a lack of crew coordination in response to the emergency. The right engine failed from the rupture of the 9th to 10th stage removable sleeve spacer in the high pressure compressor because of the spacer's vulnerability to cracks.

Facts of the Accident

Accident NTSB ID	87-01
Airline	Midwest Express Airlines, Inc.
Model aircraft	DC-9-14, N100 serial No. 47309
Year shipped	1968
Aircraft manufacturer	McDonnell-Douglas
Engine type	JT8D
Engine manufacturer	Pratt & Whitney
Date	09/06/85
Time	1521
Location	General Billy Mitchell Field, Milwaukee, Wisconsin
Country	USA
IFR or VFR?	IFR
Fatalities	31
Injuries	-
Fire during flight?	Y-engine
Fire on the ground?	Y
Probable cause	The flightcrew's improper use of flight controls in response to the catastrophic failure of the right engine during a critical phase of flight, which led to an accelerated stall and loss of control of the airplane.
Contributing causes	Contributing to the loss of control was a lack of crew coordination in response to the emergency. The right engine failed from the rupture of the 9th to 10th stage removable sleeve spacer in the high pressure compressor because of the spacer's vulnerability to cracks.
Weather conditions	Clear with visibility of 10 miles
Total crew size	4
Cockpit crew size	2
Cabin crew size	2

Passengers	27
Report ID	NTSB/AAR-87/01
Pages	105
Day or night?	Day
Flight number	105
Flight origin	General Billy Mitchell Field, Milwaukee, WI
Flight destination	Madison, WI
Description	During takeoff, the aircraft experienced a loud noise as the right engine failed. Shortly thereafter, the aircraft entered a steep descent and crashed in an open field. All 31 crew and passengers were fatally injured.

EXECUTIVE SUMMARY

At 1521 c.d.t. on September 6, 1985, Midwest Express Airlines, Inc., Flight 105, a McDonnell-Douglas DC-9-14 airplane, crashed into an open field at the edge of a wooded area about 1,680 feet southwest of the departure end of runway 19R shortly after taking off from General Billy Mitchell Field, Milwaukee, Wisconsin. The weather was clear with visibility 10 miles. During the initial climb, about 450 feet above ground level (a.g.l.), there was a loud noise and a loss of power associated with an uncontained failure of the 9th to 10th stage high pressure compressor spacer of the right engine. Flight 105 continued to climb to about 700 feet a.g.l. and then rolled to the right until the wings were observed in a near vertical, approximately right 90° banked turn. During the roll, the airplane entered an accelerated stall, control was lost, and the airplane crashed. The aircraft was destroyed by impact forces and postcrash fire. The pilot, the first officer, both flight attendants, and all 27 passengers were fatally injured.

The Safety Board evaluated the performance characteristics of the DC-9-14 airplane following an abrupt loss of power from the right engine in the takeoff phase of flight and found the airplane to be docile, easily controllable, and requiring no unusual pilot skills or strength. Therefore, the Safety Board examined those factors which might have caused the pilots to lose control, including the possibility that fragments of the right engine separated with sufficient energy and trajectory to cause critical damage to the airplane's flight control system; the possibility of control system malfunction(s), which could have rendered the airplane uncontrollable; and the possibility of inappropriate flightcrew response to the emergency.

It was determined that the loss of control was precipitated by improper operation of flight controls, specifically the introduction of incorrect rudder pedal forces about 4 to 5 seconds after the right engine failure, followed by aft control column forces, which allowed the airplane to stall at a high airspeed (accelerated stall). Thus, the Safety Board evaluated flightcrew training of Midwest Express pilots at Republic Airlines, the use and limitations of visual flight simulators used in training, and emergency procedures used by, Midwest Express.

Additionally, the Safety Board evaluated factors which might have contributed to the right engine failure, including

overhaul and inspection practices at AeroThrust Corporation, Federal Aviation Administration (FAA) surveillance at AeroThrust, and FAA and Pratt & Whitney responses to previous removable sleeve spacer failures in JT8D engines.

The National Transportation Safety Board determines that the probable cause of the accident was the flightcrew's improper use of flight controls in response to the catastrophic failure of the right engine during a critical phase of flight, which led to an accelerated stall and loss of control of the airplane. Contributing to the loss of control was a lack of crew coordination in response to the emergency. The right engine failed from the rupture of the 9th to 10th stage removable sleeve spacer in the high pressure compressor because of the spacer's vulnerability to cracks.

During the investigation, the Safety Board issued three recommendations to the FAA related to JT8D removable sleeve compressor spacers. As a result of its investigation, the Safety Board also issued two recommendations on flightcrew training in response to emergencies during the initial climb phase and one recommendation on qualifications for Principal Operations Inspectors. All three recommendations were issued to the FAA.

1. Factual Information

1.1 History of the Flight

Midwest Express Airlines (Midwest Express) Flight 206, a McDonnell Douglas DC-9-14 airplane with United States registry N100ME, arrived at General Billy Mitchell Field, Milwaukee, Wisconsin, at 1315 c.d.t.¹ on September 6, 1985. The flightcrew that was later to take flight 105 began their duty day as the crew on the continuation of flight 206 to Madison, Wisconsin. The oncoming crew was advised that no discrepancies had been noted during the initial preflight inspection of the aircraft that morning, and that no discrepancies were noted following a subsequent walkaround inspection at an intermediate stop. The airplane reportedly was "running fine" with only minor discrepancies that were not related to powerplant or flight control systems. The oncoming flightcrew reported no additional discrepancies during the continuation of flight 206, which departed Milwaukee at 1336 and arrived in Madison at 1355.

At Madison, N100ME was designated as flight 105; the crew did not change. The flight was scheduled to proceed to Atlanta, Georgia, with an intermediate stop in Milwaukee. Flight 105 departed Madison at 1425 and arrived at Milwaukee, on time and without incident, at 1441.

About 1449, the first officer of flight 105 contacted Milwaukee Tower to request an instrument flight rule (IFR) clearance to Atlanta. The clearance was received and read back by the first officer at 1450. At 1453, the captain contacted the Midwest Express dispatch facility in Appleton, Wisconsin, and received a briefing regarding his route of flight to Atlanta. The weather package applicable to the route of flight was forwarded to the captain via teleprinter. The Atlanta forecast included a 1,000-foot ceiling, visibility—2 miles, thunderstorms and rain showers. An alternate destination was planned in the event the flight could not land in Atlanta. Contingency fuel was added for possible en route diversions around the thunderstorms. The total dispatch fuel was 19,500 pounds. A loading schedule was forwarded to the flightcrew for verification and completion. The completed loading schedule indicated that the flight would be conducted within the applicable weight and balance limitations. The takeoff weight was approximately 77,122 pounds, the recommended stabilizer trim setting was 2.2 units nose-up, and the center of gravity was 29 percent mean aerodynamic chord. No hazardous material was manifested aboard the airplane.

The captain signed the dispatch release, which listed the previously noted minor discrepancies. He did not report

any other mechanical irregularities or discrepancies. At 1512, the Before Engine Start Checklist was read and accomplished in accordance with Midwest Express operating procedures. Engine start was commenced at 1514. The After Start Checklist was accomplished about 1515, although the first officer did not report that the checklist was completed, as directed by the Midwest Express Crew Operating Manual (COM). The first officer requested clearance to taxi to runway 19R for departure; his request was approved at 1516:31. A Midwest Express service agent, who walked around the airplane to ensure all doors and panels were closed, reported that everything looked normal before the airplane departed the gate. Another agent reported that there were no fluid leaks after engine start.

About 1517:50, the Taxi Checklist was completed in accordance with the COM, and the engine pressure ratio (EPR) and airspeed reference² bugs were set to 1.91 and 133 knots, respectively. (The referenced indications were correct for the departure conditions applicable to flight 105.) The Safety Board determined that the correct takeoff speeds for a 20° flap takeoff were: takeoff decision speed (V1)-123 knots indicated airspeed (KIAS), rotation speed (VR)-127 KIAS, and takeoff safety speed (V2)-133 KIAS. At the conclusion of the Taxi Checklist, the captain advised the first officer "Standard briefing ..."3

At 1519:15, the first officer reported to the tower local controller, "Milwaukee, Midex⁴ 105, ready on 19R." Flight 105 was cleared to "position and hold" on runway 19R. The captain called for the Before Takeoff Checklist, which was completed in accordance with the COM at 1519:39. The crew did not mention any aircraft discrepancies during the preparation for departure. Flight 105 was cleared for takeoff at 1520:28; the first officer acknowledged the clearance. The captain operated the flight controls, and the first officer handled radio communications and other copilot responsibilities during the takeoff.

The Midwest Express DC-9 Flight Operations Manual required the use of standard noise abatement takeoff procedures during all line operations, unless precluded by safety considerations or special noise abatement procedures. (See appendix C.) At the time flight 105 departed, noise abatement procedures were in effect. Midwest Express also utilized "reduced thrust" takeoff procedures (at the captain's discretion) to extend engine life. The applicable EPR reduction associated with this procedure was from 1.91 to 1.90. Review of the recorded cockpit communications confirmed that the flightcrew was complying with the reduced thrust and standard noise abatement takeoff procedures.

At 1521:26.4, when the airplane was about 450 feet above the runway, there was a loud noise⁵ and a noticeable decrease in engine sound. The captain then remarked "What the # was that?"6 The first officer did not respond. At 1521:29, the local controller transmitted, "Midex 105, turn left heading 175." The local controller later testified that at the time of his transmission he observed smoke and flame emanating from the right airplane engine. At 1521:29.5, the captain asked the first officer, "What do we got here, Bill?" The first officer did not respond to the captain but advised the local controller, "Midex 105, roger, we've got an emergency here." Two seconds later, the captain said, "Here"; again there was no response. There were no further communications from the flight. Neither pilot made the call outs for "Max Power" or "Ignition Override-Check Fuel System," which were part of the Midwest Express "Engine Failure after V1" emergency procedure.

About 100 witnesses saw flight 105 depart runway 19R. Most of the witnesses reported that the takeoff appeared normal until the airplane reached an altitude of about 300 feet above ground level (a.g.l.). Liftoff reportedly occurred between the midfield taxiway and the intersection of runways 19R and 25L. Many witnesses reported that they saw smoke and/or flames coming from the right engine when the airplane was about 300 feet a.g.l. and that they heard one or more loud "bangs, similar to a shotgun report," which attracted their attention to the Midwest Express airplane. None of the witnesses described smoke or flames coming from any part of the airplane other than the right engine. None of the witnesses reported seeing parts falling from the aircraft in flight. They said flight 105 continued to climb briefly, apparently maintaining runway heading for a few seconds. Twenty witnesses said the

airplane yawed and porpoised and/or that the wings rocked briefly, following the right engine failure. Several witnesses said that the nose then came downward to a near-level attitude; some of the witnesses said the airplane also appeared to have decelerated near the apex of its climb. The witnesses indicated that the airplane then rolled abruptly to a steep right bank, which increased to at least 90°. Witness accounts of the airplane maneuvers during its descent to the ground varied greatly. Most witnesses said that the airplane made 1 to 1 1/2 rotations in a nose-low spin in a right-hand direction. The airplane crashed into rolling terrain about 1680 feet southwest of the departure end of runway 19R.

The crash occurred at 1521:41, during daylight hours, in visual meteorological conditions, at 42°55'38" North latitude and 087°54'06" West longitude. All 31 occupants of the airplane were fatally injured.

1.2 Injuries to Persons

Injuries	Crew	Passengers ⁷	Others	Total
Fatal	4	27	0	31
Serious	0	0	0	0
Minor/None	0	0	0	0
Totals	4	27	0	31

⁷One nonrevenue passenger, who was authorized to use the cockpit jumpseat and was seated in the cabin, is included in the figures representing passenger injuries.

1.3 Damage to Aircraft

The airplane was destroyed by impact forces, explosion, and postcrash fire.

1.4 Other Damage

The impact and postcrash fire caused damage to low lying vegetation, trees, and a fence within a wildlife preserve.

1.5 Personnel Information

Both pilots met all Federal Aviation Administration (FAA) requirements applicable to their respective crew positions. (See appendix B.) Both pilots had received upgrade training, which led to Midwest Express DC-9 captain qualifications.

The captain, 31, was employed by Midwest Express as a DC-9-14 first officer on February 3, 1984. He upgraded to captain on February 7, 1985. At the time of his upgrade, he had accumulated 4,600 flight-hours, including 600 hours as first officer in the DC-9-14. He held an airline transport pilot certificate, which was issued on April 18, 1984, and a DC-9 type rating, which was issued on February 7, 1985. Company records indicated that, at the time

of the accident, he had 5,100 hours total flight experience, including 1,100 hours in the DC-9-14 and 500 hours as captain. All of his turbojet experience was in the DC-9. Before his employment with Midwest Express, the captain was employed as a corporate pilot flying the Beech 90 turboprop Kingair. He had logged 2,900 hours in the Kingair, including 800 hours as pilot-in-command. According to Midwest Express, he had 104 hours total instrument pilot experience when hired.

The first officer, 37, was employed by Midwest Express on February 3, 1984, and received a DC-9 type-rating on February 15, 1984. At that time, he had accumulated 4,100 flight-hours, including about 500 hours as first officer in the DC-9-14. He had obtained the DC-9-14 pilot experience as an employee of K-C Aviation, Midwest Express' parent corporation. Company records indicated that, at the time of the accident, the first officer had 5,197 hours total flight experience, including 1,640 hours in the DC-9-14, and 1,140 hours as a DC-9-14 captain. The first officer had previous turbojet experience as an F-4 pilot in the U.S. Air Force.

The pilots of flight 105 reported for duty on September 6, 1985, by telephoning their dispatch office in Appleton, Wisconsin, from the Midwest Express flight office at Mitchell Field in Milwaukee. It was the second day of a scheduled 2-day trip. The pilots shared captain responsibilities by alternating days as captain. The pilot who occupied the captain's (left) seat and assumed the responsibilities of captain on September 6, 1985, served as first officer on the preceding day. Similarly, the pilot who was the first officer on the accident flight had assumed the responsibilities of captain on September 5, 1985. Midwest Express reported that it was very unusual for two of their line captains to fly together, although check airmen flew with other captains fairly frequently (7-8 times per month). The captain and first officer of flight 105 had flown together before their current 2-day trip.

A review of both pilots' recent past activities revealed no evidence of medical problems or life situational stress problems which were present at the time of the accident. Their eating and resting habits were not remarkable.

The captain's most recent simulator proficiency check was on February 6, 1985, at Republic Airlines, and his most recent DC-9 line check was performed by a Midwest Express check airman on March 6, 1985. He completed recurrent DC-9 ground training on May 11, 1985. The captain's simulator training records reflected that "Takeoff with Simulated Powerplant Failure" was practiced in 12 sessions, "Approach to Stalls" was practiced in 12 sessions, and "Powerplant Failure/Fire" was practiced in 10 sessions. His flight instructor at Republic Airlines said the captain practiced one simulated engine failure on takeoff on a training flight, but FAA records indicated that he was not checked on that maneuver in the airplane during his type-rating checkride.

The first officer received his captain upgrade training at Republic Airlines. He also received check airman training at Republic Airlines in June 1984. However, his training records did not show that he had received all of the required check airman ground training. The FAA Principal Operations Inspector, who was assigned oversight responsibilities at Midwest Express, accepted the verbal assurance of the carrier that the required training was completed, without checking the training records of the pilot. After the pilot's ability to conduct check airman responsibilities was evaluated on May 14, 1985, he was authorized to perform proficiency and line checks in the DC-9 airplane and flight simulator. The Safety Board established that the check airman training records were incomplete. Whether the required training was conducted, but not documented in the training records, could not be established.

The first officer's most recent proficiency and line checks were completed on August 26, 1985, and March 21, 1985, respectively. Both checks were conducted by Midwest Express check airmen. The first officer's most recent DC-9 ground training was completed on November 10, 1984. Training records indicated that the first officer practiced "Takeoff with Simulated Powerplant Failure" in 15 simulator sessions, "Approaches to Stalls" in 12 simulator sessions, and "Powerplant Failure/Fire" in 14 simulator sessions. His flight instructor at Republic Airlines said he gave the first officer a simulated engine failure during climbout at least once in the airplane. He did not recall the details of the flight, but he said that he normally simulated an engine failure after takeoff in the airplane at 300 to

500 feet a.g.l. by retarding the throttle to a point (above 67 percent N2) where the engine would not unspool.⁸

Neither pilot had experienced an engine failure in his DC-9 line flying experience. Both pilots were "trained to proficiency" during captain upgrade training at Republic Airlines and were considered by their peers and instructors to be excellent pilots.

Midwest Express did not provide its pilots with a specific course on cockpit resource management (crew coordination), but training and management personnel stated that the applicable principles were stressed in the training of each pilot.

1.6 Aircraft Information

1.6.1 Aircraft and Engine Historical Information

N100ME, a McDonnell Douglas DC-9-14, serial No. 47309 (fuselage No. 393), was owned and operated by Midwest Express Airlines, Inc. Midwest Express Airlines is owned by K-C Aviation Inc., a wholly owned subsidiary of the Kimberly Clark Corporation. Midwest Express acquired N100ME from K-C Aviation on June 8, 1984, and operated the airplane until the date of the accident. According to Midwest Express records, the total airplane operating hours and cycles were 31,892 hours and 48,903 cycles, respectively, at the time of the accident.

N100ME was manufactured in 1968 and was delivered to the Linea Aeropostal Venezolana (LV) on October 23, 1968. It was sold to Aerovias Venezolanas, S.A. (Avensa, VE) on October 15, 1976, and then to K-C Aviation on January 20, 1983.

A review of the maintenance records for N100ME indicated that the airplane had been maintained in accordance with Midwest Express Airlines procedures and FAA regulations. On the day of the accident, the airplane was being operated with two deferred maintenance items in accordance with the minimum equipment list (MEL): left auto temperature control inoperative (MEL No. 99, dated August 28, 1985) and right cockpit fluorescent light switch inoperative (MEL No. 100, dated August 28, 1985). There were no deferred items related to the powerplants or to the flight control systems. The maintenance records indicated that the requirements of all applicable Airworthiness Directives had been met. Midwest Express maintenance records indicated that inspections and checks required to assure continuous airworthiness of N100ME had been accomplished according to schedule.

N100ME was equipped with two Pratt & Whitney model JT8D-7B turbofan engines. Neither engine was part of the equipment on the airplane when it was delivered in 1968. The left and right engines had accumulated 8,391 hours and 5,935 hours, respectively, since their last engine heavy maintenance (EHM). The left engine, S/N P657718, was installed on N100ME on August 19, 1984. The right engine, S/N P654106, was installed on N100ME on January 13, 1983.

The last recorded EHM of the right engine was performed at Air Carrier Engine Service (A.C.E.S.), now AeroThrust Corporation, in Miami, Florida, in September 1979. Engine records showed that the high pressure (H.P.) compressor 9-10 stage removable sleeve-type spacer (P/N 557340, S/N DAL 81374) from another engine (S/N P657255) was installed in engine S/N P654106 (later the right engine on N100ME) at that time. (See figure 1.) Engine records for the period before 1979 were not available to document the service history of the spacer; thus, the total operating time of the failed spacer was not known. The 9-10 stage H.P. compressor removable sleeve-type spacer is not a life-limited part.

Engine maintenance records showed that the owner of engine S/N P654106 returned the H.P. compressor to

A.C.E.S. for refurbishment in October 1981. The H.P. compressor 9-10 spacer was repaired, inspected, and reinstalled following that rework. The A.C.E.S. Part Routing Tag for the 9-10 spacer, dated October 12, 1981, revealed the following operations, according to AeroThrust management:

A "Reject" stamp dated October 9, referred to a damaged knife edge airseal. The airseal was reworked by blending⁹ the damaged area. The tubes were removed and the spacer nickel cadmium (NiCd) coating was stripped. The inside diameter was grit-blasted. The spacer was then examined using fluorescent magnetic particle inspection (FMPI) equipment and passed inspection.

The spacer was then replated (although not signed off) and the tubes were reinstalled. The spacer was machined and inspected one more time before installation in the engine.

There was no record of the nature of the previous damage which had necessitated the rework. The specifications regarding airseal blending of the 9-10 spacer allowed machining down to the inside radius, above the pedestal, to a maximum width of 2 inches in one area, or a maximum width of 4 inches for all areas. There is no record of the amount of blending that was performed.

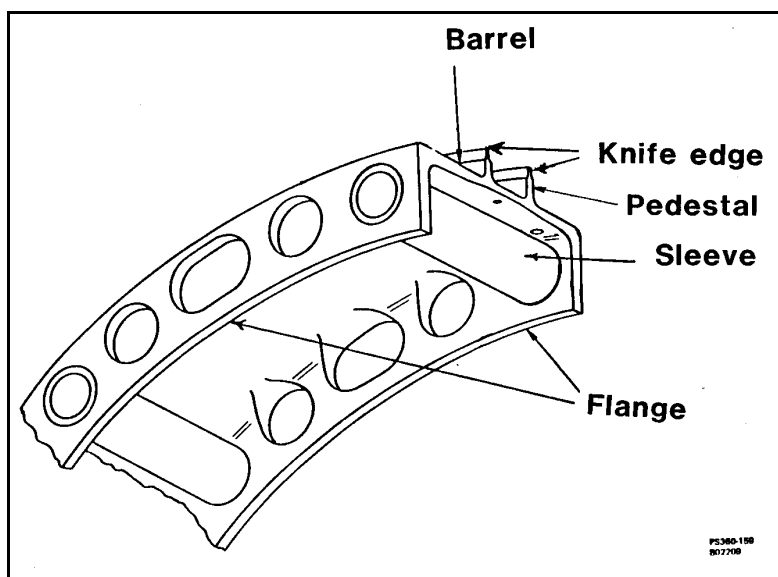

Figure 1.—Main features of a removable sleeve compressor spacer.

On the day of the accident, the right engine had been in service 20,207 hours. It had operated 3,792 hours and 2,584 cycles since the 1981 H.P. compressor refurbishment. No major repairs had been performed on the right engine since its installation in January 1983, and no discrepancies had been noted for the right engine in the 30 days before the accident.

The left engine, S/N P657718, was purchased by Midwest Express from Ansett Airlines (Australia) in May 1984. The engine was inspected, test run, and determined to be serviceable by AVIALL of Dallas, Texas, before it was installed in the left position of N100ME on August 19, 1984. The left engine had been operated 23,939 hours and 25,394 cycles before the accident flight. No major repairs were noted in the engine log since the August 1984 installation, and no discrepancies were recorded for the left engine in the 30 days before the accident.

Midwest Express used an in-flight monitoring program to track the performance of its JT8D engines. Review of the

engine monitoring records from July 8, 1985, through September 3, 1985, revealed no adverse trends that would indicate a performance problem in either engine installed on N100ME.

1.6.2 Certification of the DC-9-14

The DC-9-14 was certificated as a transport category aircraft on November 23, 1965. Part 4b, Airplane Airworthiness Transport Categories, of the Civil Air Regulations required that the manufacturer:

- Demonstrate that the airplane was "safely controllable and maneuverable during takeoff, climb, level flight, descent and landing" (4b.130(a)).
- Demonstrate that it was possible to make a smooth transition from one flight condition to another, including turns and slips "without requiring an exceptional degree of skill, alertness or strength on the part of the pilot ... under all conditions of operations normally encountered in the event of sudden failure of any engine" (4b.130(b)).
- Demonstrate that, while holding the wings approximately level, it was possible to execute reasonably sudden changes in heading, in either direction, without encountering dangerous characteristics, even with an engine inoperative. Also, the manufacturer was required to demonstrate that it was possible to execute 20° banked turns with and against the inoperative engine. (4b.132); and
- Determine a minimum control speed (V_{mc})¹⁰ so that when the critical engine was suddenly made inoperative, at that speed, it was possible to recover control of the airplane, with the engine still inoperative, and maintain straight and level flight at that speed, either with zero yaw or, at the option of the applicant, with an angle of bank not in excess of 5°. V_{mc} speed was not to exceed 1.2 times the stalling speed of the aircraft (4b.133). During that maneuver, take-off, or maximum available power, was to be maintained on the remaining engine.

1.6.3 Airplane Flight Control Systems

The DC-9-10 series airplanes (including the -14 model) have conventional aileron, rudder, and elevator control systems. The horizontal stabilizer is adjustable for longitudinal trim. Lateral control is aided by hydraulically operated flight spoilers. The rudder normally is powered hydraulically with automatic reversion to cable operated aerodynamic tab control when hydraulic power is not available. A yaw damper aids directional stability, but a yaw damper operation is not required for flight by the minimum equipment list.

Additionally, a mechanism limits rudder travel at speeds above approximately 176 knots. Cable and hydraulic system redundancy is provided to minimize the risk of loss of aircraft control in the event that individual component parts of the control system are disabled in flight. The main control cables, the trim cables, and the hydraulic lines, which pass through the aft fuselage adjacent to the engines, are located below the cabin floor, well below the top of the right engine. (See appendix G for a detailed discussion of relevant flight controls and aircraft systems operation.)

1.7 Meteorological Information

At the time of the accident, the sky over General Billy Mitchell Field was clear. Weather conditions in the Milwaukee area were characterized by scattered clouds and moderate southwesterly winds. The surface weather observations at General Billy Mitchell Field were:

1451, Surface Aviation: Clear, visibility--10 miles; weather--none; temperature--89° F, dew point--76° F; wind--230° at 15 knots, gusting to 20 knots; altimeter--29.83 inHg; remarks--few cumulus and cirrus east.

1540, Local: Clear, visibility--10 miles; weather--none, temperature--90° F, dew point--76° F; wind--220° at 15 knots, gusting to 20 knots; altimeter--29.83 inHg; remarks--few cumulus, aircraft mishap.

Based on the 1451 observation, the density altitude was determined to be 3,200 feet.

A wind gust recorder, ¹¹ operated by the National Weather Service at Mitchell Field and located at the intersection of runways 19R and 25L, showed a range of wind speeds from 9 to 22 knots from 1500 to 1600. The wind decreased from 18 knots at 1515 to 10 knots at 1520 and then it rapidly increased to 17 knots at 1521:30 and dropped rapidly to 12 knots at 1522:30. At 1516, the Milwaukee tower local controller advised Midex 105 that the wind was from 210° at 16 knots.

1.8 Aids to Navigation

Not applicable.

1.9 Communications

There was no evidence of radio communication difficulties between flight 105 and Milwaukee Tower controllers on the day of the accident. The Daily Record of Facility Operations indicated that all air traffic control tower equipment was operating satisfactorily at the time of the accident.

1.10 Aerodrome Information

General Billy Mitchell Field is 723 feet above mean sea level (m.s.l.) and is located 6 miles south of downtown Milwaukee. It is served by five runways. Runway 19R was 9,690 feet long by 200 feet wide, and it was oriented to 187.1° magnetic. It had a concrete and asphalt surface which was wire combed and grooved. Runway 25L was 8,010 feet long by 150 feet wide, was surfaced with asphalt and concrete, and was grooved. The airport is certificated for air carrier operations under 14 CFR 139.

Milwaukee Tower is equipped with an ARTS III ¹² terminal radar computer system which utilizes radar data obtained from an ASR-8 ¹³ radar located on the airport. Recorded radar data associated with the Midwest Express assigned transponder code 5631 were retrieved and utilized to reconstruct a track of the ground and flight progress of flight 105. The ARTS III radar data could not be used to reconstruct the tracks associated with nontransponder

(primary) targets, such as engine debris.

1.11 Flight Recorders

N100ME was equipped with a Fairchild 5424 foil type analog flight data recorder (FDR), S/N 7379, and a Fairchild model A-100 cockpit voice recorder (CVR), S/N 875. The FDR sustained mechanical damage but revealed no evidence of internal exposure to fire or smoke. The magazine containing the foil recording medium was undamaged. All parameter and binary traces were present and active; however, the auxiliary binary traces, which are normally used to record indications of radio transmissions, were not functioning during the accident flight. The CVR casing suffered mechanical and fire damage but the recording medium was undamaged. The quality of the recording was good. All of the CVR channels were working.

1.11.1 Flight Data Recorder

The FDR was recovered from the wreckage and was forwarded to the Safety Board's Flight Recorder Laboratory in Washington, D.C. It contained indicated airspeed, indicated altitude, heading and normal acceleration ¹⁴ data. (See appendix F.) Inspection of the FDR foil recording medium indicated that there was a gap in the data starting at FDR time 00:53.5 (1521:26.4). The gap was equivalent to about a 4-second time interval. At the end of the gap, several data points, normally recorded at 0.55-second intervals, were recorded as if they had occurred simultaneously.

The gaps in the FDR data during the accident flight were attributed to a jump in the foil position which probably resulted from airframe vibration and occurred about the time the right engine failed. The time correlation of the measured parameters was achieved by aligning the gaps in the recording. Subsequent correlation of the FDR and CVR data revealed that the "clunk" sound on the CVR occurred at the same time as the beginning of the gap.

1.11.2 Cockpit Voice Recorder

The CVR revealed that the takeoff appeared normal to the flightcrew. There was no recorded conversation to indicate that the captain relinquished control of the aircraft to the first officer, or that the first officer communicated any intention to assume control of the aircraft during the flight. The CVR did not record any conversation or other indications which would confirm the extent to which the crew recognized the nature of the emergency, nor did it reveal what actions were taken by the crew to respond to the emergency. (See appendix E.)

The No. 1 channel of the CVR was connected to the passenger intercom system. The recording was 32 minutes long but only the last 7 minutes were transcribed, encompassing the time from engine start until the end of the recording. The transcript begins at 1514:33 c.d.t. with the start of the No. 2 engine. The engine power increase, associated with the commencement of the takeoff, occurred at 1520:43. The engine volume and frequencies, which were measured on a sound spectrum analyzer, seemed normal until 1521:26.4, when a loud "clunk" sound was heard. Almost immediately following the "clunk," the rpm of one of the engines decreased noticeably. At 1.2 seconds after the "clunk," the captain exclaimed, "What the # was that?" At 1.5 seconds after the "clunk," the rpm of the second engine began to decrease, but at a slower rate than the first. The captain asked, "What do we got here Bill?" There was no response from the first officer. Analysis of sounds recorded by the CVR revealed that the stall warning stickshaker activated at 1521:36.0 and continued until the end of the recording. Two seconds after the stickshaker activated the captain exclaimed, "Oh ...". Shortly afterward, the airplane's altitude began decreasing rapidly. One flight attendant, exclaimed "Heads down" three times. The electrical power to the CVR was

interrupted at 1521:38.8 for about 0.1 second. At 1521:41.7 (2/10 of a second before the recorder stopped) a single "whoop" could be heard from the ground proximity warning system.

1.11.3 CVR Sound Spectrum Examination

The CVR recording was examined using the NTSB Audio Laboratory's Spectral Dynamics SD-350 sound spectrum analyzer to document the sounds which were in frequency ranges normally associated with engine operation. Some of the sounds heard were in the 70-200 Hertz (Hz) range. Sounds produced by the rotation of the high pressure compressor (N2) of a JT8D engine are in this frequency range. Those sounds were measured starting at engine spool-up before takeoff and continued until 1521:41.

Sounds similar to those produced by the fan section (N1) of the JT8D engine (in a higher frequency range) were identified but were not heard until about 3 seconds before the loud "clunk" at 1521:26.4. The N1-type sounds, which were very faint and could not be heard after the stickshaker activated at 1521:36.0, were determined to have emanated from the left engine. Fan section speed was calculated by dividing the number of first stage fan section blades (30) into the blade passing frequency ¹⁵ documented by the sound spectrum analyzer printout. Similar calculations were conducted for the N2 fan section. These calculations were used to evaluate the N1 and N2 values during the period in which the loud "clunk" was recorded on the CVR and beyond. The N1 and N2 values revealed that:

1. The right engine rpm, as measured by N2, fell off rapidly immediately following the loud "clunk"; and
2. The left engine rpm, as measured by N1 and N2, fell off at a slower rate starting about 1.5 seconds after the "clunk" sound.

1.11.4 Time Correlation of CVR, FDR, Radar, and Air Traffic Control Information

The data available from the CVR, the FDR, the air traffic control (ATC) transcript, and the recorded (ASR-8) radar data incorporated different reference times. The CVR timing (elapsed time) was correlated to the ATC transcript timing and the radar data timing, which were based upon universal coordinated time (UTC). The timing of the FDR was correlated with the radar data by comparing plots of radar and FDR-indicated altitudes which preceded the engine "clunk." The correlation between CVR and FDR data was performed by overlaying the CVR time line over the plotted FDR data. Several points were time correlated such as the gap/engine clunk point, the 100-knot callout, the V1 callout, and the ends of the recorded CVR and usable flight data. (See appendix F.)

1.11.5 Static Pressure Error

At 00:57 FDR elapsed time (1521:30), the FDR data indicated an excessive increase in the climb-rate, while the vertical acceleration data indicated a reduction of normal acceleration forces from about 1 G to about 0.3 G. The reduced G load suggested forward control yoke input and a reduced climb rate, contrary to the recorded altitude data, but consistent with witness observations.

The rapid increase in FDR-indicated altitude revealed that the indicated aircraft climb performance was in error and contrary to the known performance characteristics of the airplane. It had been expected that a reduction in G load

below 1.0, would have decreased the rate of climb, yet the FDR indicated a rapid increase in altitude. By integrating the accelerometer data, the maximum altitude which the airplane actually reached was determined to be about 1,400 feet m.s.l., not the indicated 1,570 feet m.s.l. Douglas Aircraft Company flight test data showed that the difference, 170 feet, could have resulted from static pressure error. Information, interpolated from Douglas flight test data, revealed that the 170-foot indicated altitude error (higher than actual) was consistent with a sideslip ¹⁶ angle of about 15°. Such a sideslip, according to the Douglas data, would produce a static pressure error and false indications in the instruments which are dependent upon pitot-static information. The static pressure source for the FDR is the airplane's alternate static pressure source. The captain's and first officer's altitude and airspeed instruments (and vertical speed) used the normal pitot static system, which is less sensitive to sideslip-induced errors. Thus, while a 15° sideslip would cause the FDR to record airspeed about 14 knots too high, the same sideslip would cause the cockpit instruments to reflect only about 2/3 of the FDR airspeed (9 knots) and altitude error (113 feet).

1.11.6 Aircraft Flight Profile Information Based On Recorded Data

The FDR foil revealed that the takeoff roll and liftoff were normal, with liftoff occurring near the intersection of the midfield taxiway and runway 19R, about 4,200 feet from the start of the takeoff roll. Rotation to the takeoff attitude occurred at 140 knots. N100ME accelerated to 168 knots with a rate of climb of about 3,000 feet/minute, indicating a normal two-engine initial takeoff flightpath. N100ME was about 7,600 feet down the runway when it reached a height of 450 feet above the ground and when the right engine failed. Radar data indicated that the airplane was near the left edge of runway 19R at engine failure. This displacement left of the runway centerline was considered in evaluating the distribution of engine parts, which were found near the runway, in analysis of the trajectory of engine parts. The heading trace showed that N100ME continued essentially straight ahead for the first 4 seconds after the right engine failure. Radar data confirmed the tracking of the airplane essentially straight ahead.

Four seconds after the right engine failure, the FDR heading trace began to deviate substantially to the right (from about 194° to a heading of 214°) over a 5-second period (4° per second). The heading then deviated to the right at a more rapid rate (to 260°) in the next 3 seconds (15° per second). Comparing the heading change to the radar track of the flight revealed that part of the heading change, that is, the difference between the actual track and the heading, was due to sideslip. The sideslip began about 4 seconds after the right engine failure and increased rapidly in the next few seconds.

For about 3 seconds after the right engine failure, the FDR vertical acceleration trace remained at about 1 G. It then dropped sharply to about 0.3 G in the next second before increasing to a value of 1.8 G. The FDR and aerodynamic data indicated aircraft stall at the point where vertical acceleration reached 1.8 G.

Based upon a 14-knot FDR airspeed error due to sideslip and induced static pressure error, the actual airspeed loss from right engine failure to stickshaker would have been about 17 knots. Correcting the FDR data for sideslip and static pressure error revealed that the aircraft stalled about 148 knots equivalent airspeed (KEAS), ¹⁷ or about 156 KIAS (crew instruments).

On the accident flight (20° flaps), the 1 G stall speed was 114 KEAS and the predicted stickshaker speed was 118 KEAS. When aircraft loading is in excess of 1 G flight, the aircraft will stall at a higher speed (accelerated stall), consequently increasing the stickshaker activation speed. Similarly, when the aircraft is rolling, the stickshaker speeds increase. The following table reflects the predicted variations in stickshaker speed as functions of load factor and roll rate. The stickshaker stall warning device is dependent on angle of attack. Deceleration at a rate in excess of 1 knot per second and/or abrupt pullup maneuvers would reduce the 4-second warning time normally provided by the stickshaker stall warning system.

Roll Rate Degrees/Second <u>Degress/Second</u>	Stickshaker Speeds (KEAS) with 1.0 G Load Factor	Stickshaker Speeds (KEAS) with 1.5 G Load Factor
0	118	144
5	120	146
10	122	148

1.12 Wreckage and Impact Information

1.12.1 General

N100ME struck the ground in a clearing, in a relatively level, partially wooded field. Ground elevation of the initial impact point was about 680 feet m.s.l. Initial contact was at the northern end of a 275-foot-long wreckage path where there were two parallel gouges about 14 feet apart and which were initially 4 to 5 inches wide. One gouge was 28 feet long, and the second gouge was 80 feet long. Both gouges were oriented to 185°. Pieces of the right elevator and horizontal stabilizer were imbedded at a 90° angle to the ground along the length of the 28-foot gouge. The width of the 80-foot gouge gradually increased to 5 feet 5 inches at the southernmost end and contained right wing fragments. Pieces of the right wing tip were identified at the north end of the 80-foot gouge. The right engine was lying across the midpoint of the gouge. Beyond the initial gouges, the remainder of the wreckage of N100ME was strewn about a 200-foot-wide path.

The wreckage was fragmented and was largely consumed by fire. Airplane pieces, ground, and trees in this area were blackened and scorched by fire. Pieces of all flight control surfaces and the extremities of the airplane, such as nose, wingtips, tail surfaces, and engines, were found in the impact area.

Engine-related parts from the right engine were found up to 200 feet to the left side and between 7,400 and 8,200 feet south of the north end of runway 19R. The parts included compressor blades from the 9th and 10th stages of a Pratt & Whitney JT8D engine and parts, which totaled 90 percent, by weight, of a 9th to 10th stage (9-10) high pressure compressor spacer. With the exception of the engine-related parts found on and adjacent to runway 19R, the wreckage of N100ME was recovered from the airplane impact area. (See appendix D.)

The attitude and flightpath angle of the airplane at impact were estimated by pictorially aligning the ground scars with the corresponding airplane parts. Using a scale drawing of the airplane, the right wingtip was placed at the north end of the long ground scar and the flightpath of the right horizontal stabilizer was aligned with the shorter ground scar. The airplane drawing was then rotated to bring its flightpath into alignment with the end of the long ground scar. Thus, the Safety Board determined that flight 105 had impacted in about a 90° right roll with the nose about 29° below the horizon in a 31° right yaw. The flightpath immediately before impact was determined to have been about 60° downward.

1.12.2 Details of Wreckage Examination

Fuselage--the fuselage was fragmented and burned. Most of the identifiable nose section components were found near the south end of the wreckage path. Aft fuselage pieces were found from the north end of the wreckage path to a point 156 feet from the initial impact point. Pieces of the aft fuselage were examined for potential punctures which might have occurred if parts ejected from the right engine had contacted the fuselage before ground impact. Several pieces were submitted to the Safety Board's Materials Laboratory for further examination. For example, punctures were found in the fuselage at about fuselage station (F.S.) 894, 6 inches below the right engine pylon fairing. In the vicinity of the punctures the fuselage skin was extensively torn. However, none of the fuselage skin sections which contained suspicious-looking punctures were adjacent to hydraulic lines or major control cables.

Wings--The wing structure was destroyed with pieces strewn about the crash site. The largest pieces recovered were from the left wing and included a 34-foot-long outboard section with the aileron and trim tab attached, although they were battered and partially consumed by fire. Both angle of attack vanes (stall warning system lift transducers) were recovered but the right vane had separated from the wing and was damaged. A 9-foot piece of the left wing leading edge, from approximately the vortilon¹⁸ position to the outboard end, was intact.

The vortilon was partly attached to the wing with portions burned away. The wing leading edge surfaces available for examination were smooth and revealed no evidence of surface corrosion. Several pieces of right wing leading edge were found to be smooth and free of corrosion.

Three battered and fire-damaged right aileron pieces were found near the initial impact area. Portions of both right aileron control tabs were found within the aileron structure. The left aileron, with portions of the control tabs attached, was battered, but intact and attached to the largest piece of the left wing.

All four flight spoilers were attached to their respective actuators and were found in stowed positions. All four spoiler actuators were retracted and locked. The left-hand spoiler bypass valve operating handle was found in the ON position with the lock-pin in place. The right-hand valve operating handle was missing, but the indicator was pointing to ON.

Right flap pieces were found in the initial impact area. All flap hinges and the flap hydraulic actuators were separated from the flaps. The left flap was recovered in two pieces. Each piece was relatively intact except for some fire damage at the trailing edge of the outboard piece. It was not possible to confirm the preimpact flap position from the remaining flap fragments. Both left flap actuators were recovered. Internal examination of the cylinders at the Safety Board's Materials Laboratory did not reveal marks made by the pistons at the moment of impact. Examination of the piston rods revealed bends in three rods 2 3/4 inches from the piston rod end. Comparison of McDonnell Douglas data and measurements from an airplane similar to the accident airplane revealed that the piston rods were in a position corresponding with 28° to 29° extension when they were bent.

Crew conversation, recorded by the CVR, indicated that the flaps were set at 20° for takeoff and did not reveal any indication that the flap position was changed after takeoff.

Empennage--The pitch and directional (yaw) control system pieces were battered and fire damaged. There was, however, no evidence of foreign object damage (FOD) to the actuators, push-rods, or hinge brackets. All fractures appeared typical of overload separations. The captain's and first officer's fractured left rudder pedal support arms were removed and sent to the Safety Board's Materials Laboratory for detailed examination.

The vertical stabilizer was found resting on its right side, separated from the fuselage, largely intact from its lower attachment points to the horizontal stabilizer jackscrew. Much of the left side was severely fire damaged. No punctures were found in the remaining left side skin. The right side skin of the vertical stabilizer was sooted and discolored but largely was intact. Punctures and gouges were examined carefully for evidence of contact or damage caused by ejected engine parts. All of the observed punctures were in areas which did not contain control system

components. Some of the punctures and gouged areas were removed for detailed laboratory examination.

About 12 feet of vertical stabilizer rear spar structure (from 2 feet below the fuselage/stabilizer junction to 10 feet above that junction) was intact. The spar was heat damaged and had partially melted away. This portion of the rear spar revealed no evidence of penetration or gouging damage. The two hydraulic lines for the elevator power boost system were still routed along the rear spar; the lines were intact except at the top and bottom of the stabilizer where they were broken and distorted. Broken portions of the upper and mid-hinge bracket bolts for the rudder were still mounted to the vertical stabilizer. The fracture surfaces were typical of overload damage.

The rudder was nearly detached from the vertical stabilizer and had suffered extensive fire damage. A 2-foot piece of rudder leading edge remained attached to the vertical stabilizer at the lower rudder support post. It was heavily fire damaged. The rudder sector linkage mechanisms at the base of the rudder were still attached to the rudder control tab, although heavily heat damaged. The control tab input arm at the base of the tab torque tube was broken. The bracket arm mount at the bottom of the torque tube also was broken about 4 inches from the centerline. The bracket and arms for the hydraulic actuator linkages to the rudder were intact; there was no evidence of preimpact FOD in this area. The rudder hydraulic actuator was still attached to the rudder drive arm.

A rudder section, approximately 6 feet long, which consisted of leading edge material back to the front spar and center and upper hinge areas, was recovered. The hinge brackets were broken; however, pieces of bracket structure were still attached by the pivot bolts of both the center and upper hinges. The fracture surfaces were typical of overload. The rudder damper was still attached and was movable with normal resistance. The damper control arm which attached to the vertical fin was broken. A 1 1/4- by 1/8- inch horizontal cut was found in the rudder leading edge skin approximately 2 1/2 inches above the center hinge area. The cut was at the crown of the leading edge and had penetrated the skin; however, a plate beneath the surface was not penetrated. No other penetration damage was noted.

A 17-inch piece of rudder control tab leading edge (from the base pivot point to the lower hinge) was recovered. It was heavily fire damaged; however, it exhibited no gouge damage.

The yaw damper was removed from the wreckage and disassembled. No evidence of preimpact failure or malfunction of the yaw damper was found.

The left horizontal stabilizer was severely burned. The largest remaining intact portion was a 20- by 36-inch rear center section with a piece of vertical stabilizer pivot structure attached. The right horizontal stabilizer was disintegrated. The majority of the identifiable pieces were recovered from the initial impact ground scar. No evidence of foreign object penetration or corrosion was observed in the pieces that were available for examination.

The primary and alternate electric trim actuators and planetary gearbox had broken off the jackscrew that is used to adjust the position of the horizontal stabilizer in flight. The direction of the fracture was consistent with the attitude at which the aircraft struck the ground. The length of the jackscrew extension corresponded to 2.05° airplane nose-up trim, close to 2.2 units nose-up trim set by the crew before takeoff.

Seven fragments of the right elevator, accounting for all but the aft area at the inboard end (which was burned away), were recovered from the wreckage path. There were no punctures through the recovered elevator pieces. An area of the lower trailing edge surface, which contained scrape marks, was removed for laboratory examination. There was no evidence of FOD in a 47-inch section of right elevator control tab which had separated from the elevator.

A 12-foot piece of left elevator leading edge was attached to the horizontal stabilizer. The leading edge contained no punctures. The remainder of the left elevator was consumed by fire. Similarly, the left elevator control tabs were completely burned away except for portions of their leading edges.

The elevator control tab bellcranks were still attached to the torque tubes within the horizontal stabilizer, although they were heavily fire damaged. The bellcrank ends of the elevator control cables were still attached although the other ends of the cables were broken. The broken ends had parted in a manner consistent with tension overload. On the remaining elevator and horizontal stabilizer pieces, which were not consumed by fire, no puncture marks were evident.

Flight Control Linkages and Cables.--The extensive breakup of N100ME following ground impact resulted in broken and distorted bellcranks, sectors, pulleys, and cables which had been associated with the cable control system. Four cables, which were for primary control of the elevator and rudder, were recovered from the left side of the fuselage in the area of the lavatories and outflow valve and aft of the aft pressure bulkhead. The broken ends of the cables were typical of tension overload failures. Two rudder trim cables and a stabilizer feedback cable, which had been routed along the right side of the aft fuselage, were examined. None of these cable fractures disclosed evidence of preexisting failure or material defect.

A 40-foot piece of elevator control cable, routed from within the vertical stabilizer, revealed a fracture consistent with tensile overload. Two stabilizer position cables, which had been routed through the vertical stabilizer, also had broken ends which were typical of tension overload failures.

About 200 feet of primary elevator and rudder control cable were identified and examined with regard to fracture mode and for mechanical damage. Another three sections of primary control cable, each about 22 feet long, were recovered from the vicinity of the outflow valve and were similarly examined; however, the cables could not be precisely identified. All primary elevator and rudder cable breaks were typical of tensile overload or were brittle fractures due to overheating. The sections of cable which had broken strands or which were otherwise suspect were submitted for Safety Board laboratory examination. No evidence of preexisting damage was noted.

About 115 feet of rudder trim and stabilizer position cable were examined, disclosing tensile overload and brittle fractures associated with overheating. One piece of right rudder trim cable similarly revealed tensile fractures and a brittle fracture associated with overheating.

The elevator sectors at the top of the vertical stabilizer were each in one piece but were fire damaged. The right elevator torque tube was intact with a broken end of the elevator control tab rod attached. The rod end fracture was typical of overload failure. The left elevator torque tube, including the entire elevator control rod, was still attached to the top section of the vertical stabilizer. The rod was straight with the attachment bolt to the tab still in place. The tab end of the rod was heat damaged and the tab structure had melted from around the rod end. The control rods for the left elevator geared tab were still attached to the left elevator leading edge structure. Both rods were straight with the aft attachment bolts intact. The elevator gear tab attachment brackets had melted from around the geared tab rods.

The right elevator geared tab rods were still attached to the elevator structure. Both ends of the inboard rod were still attached, one to the elevator and the other to a piece of tab structure. The outboard rod was attached at the forward end to the elevator structure but was broken at the aft end of the rod end fitting. The fracture was typical of bending overload. The right elevator control tab rod was not recovered except for the forward attachment fitting which was still attached to the torque tube structure.

Hydraulic Systems.--The hydraulic systems were fragmented and burned as a result of impact forces and the effects of the postcrash fire. The hydraulic systems were examined to determine whether there had been any interruptions to hydraulic power before impact. The hydraulic reservoirs exhibited fire and impact damage. Similarly, numerous hydraulic lines, the right auxiliary hydraulic pump, and the right hydraulic system pump/motor all exhibited extensive impact and fire damage. Eight hydraulic accumulators were recovered but were fire and impact damaged. One accumulator indicated a pressure of 500 psi. Both hydraulic system filters contained burned hydraulic fluid;

the magnetic plugs were clean.

Both elevator augmentor cylinders and the right elevator control valve were tested and found to operate normally. The left elevator control valve was fire damaged to the extent that it could not be tested. The postimpact condition of the elevator augmentors did not allow the identification of the preimpact positions.

The rudder power shutoff valve, valve sector, and crank were recovered near the airplane impact point. Examination of the rudder power shutoff valve revealed a bent control rod and discoloration which were consistent with rudder hydraulic power on. Hydraulic fluid was within the actuator reservoir. A measurement of the rudder power actuator (actuator eyebolt to rudder crank) was equivalent to 1.5° to 1.75° rudder trailing edge left of center. The rudder trim and load feel mechanism measurement was equivalent to the rudder trailing edge being 2.5° left of center. The position of the "Q" bellows hook to the rudder power cylinder actuator pushrod indicated neutral rudder. The gripper arms of the rudder tab lockout mechanism were found essentially against the roller, indicating that the mechanism was in the manual rudder position. Loss of hydraulic pressure would account for the rudder tab lockout going to the manual rudder position. The rudder hydraulic actuator exhibited no evidence of preimpact damage. The laboratory examination of the hydraulic pressure and return lines (from the rudder power actuator to about 40 inches forward of cant station 989.4) did not reveal evidence that the fractured areas had been damaged because of another object impacting the lines.

Landing Gear.--All three landing gear had separated from the aircraft structure but remained in the wreckage area. All three landing gear actuators were attached to their respective gear struts and were in the gear "up" positions. All six tires were intact. Recorded cockpit conversation disclosed that the landing gear were retracted after takeoff and did not reveal any indication that the landing gear were subsequently extended by the crew.

Right Engine.--The right engine was found resting on its right side, still attached to a portion of the pylon structure, about 40 feet south of the initial impact point of the airplane. The engine revealed evidence of a frontal impact with the ground which left dirt deposits within the right side of the inlet case. The engine exhibited impact damage but was intact from the inlet case through the thrust reverser. The engine thrust reverser was found in the stowed position.

Examination of the right engine revealed that the 9-10 stage compressor spacer had ruptured and separated from the engine, liberating all of the 9th and 10th stage compressor blades. The blade outer shrouds showed evidence of severe abrasion, typical of airfoil release at high rotational speed. There was an opening in the rear skirt of the intermediate case from the 11 to 1 o'clock position (viewed looking forward), which was 4 inches wide axially and 7 inches long circumferentially in the plane of rotation of the missing 9-10 spacer. A piece of vane shroud was protruding through the rear skirt into the fan airflow duct. There were no other holes through the compressor case. The internal damage was consistent with a sudden failure initiated by the rupture of the 9-10 spacer.

Metalization of fuel nozzles and burner can domes, thermal cracking of first stage turbine blades, and metallographic laboratory tests showed that the first and second stage turbine blades had been subjected to temperatures well in excess of normal operating temperatures; all were consistent with turbine overtemperature operation, secondary to the effects of the spacer rupture.

Examination of the 12th stage compressor blades revealed that the majority of the airfoil fractures exhibited tensile or shear characteristics. Nine blades, however, showed evidence of relatively shallow fatigue progressions with multiple origins along convex airfoil surfaces. The fatigue was typical of low cycle, high stress cracking. None of the fractures appeared to be primary in nature.

Most fan blades which were in areas of case deformation were buckled. The third and fourth stage turbine blades similarly were buckled in a manner typical of little or no rotation of the rotors at impact. The EPR transmitter linkage indicated 0.95 (subidle) at impact. Examination of the engine revealed no evidence of bird ingestion or

other significant FOD.

Both the upper and lower right engine cowlings were extensively damaged and had broken apart. Some pieces of the upper cowling, however, remained attached to parts remaining from the lower cowling, including:

1. Three of the four inboard upper cowling hinges were latched, with portions of the apron and upper cowling attached. The fourth hinge was not latched but was intact; and
2. All four outboard upper cowling latches were latched, with portions of the upper and lower cowling attached.

A 3-foot section of the forward upper cowling was recovered and contained a hole, 2 square inches in size, which appeared to have progressed from inside to outside the cowling. The location of the hole was determined to have been 16 inches forward of the plane of rotation of the 9-10 stage compressor spacer. None of the cowling pieces which had been adjacent to the hole in the engine were identifiable because of extreme distortion and tearing of the cowling. There was no evidence that the right cowling had opened before ground impact.

Left Engine.--The left engine was found in a wooded area in heavy vegetation, about 180 feet south of the right engine and near the south end of the wreckage path. The engine had sustained severe impact damage in the inlet area between the 3 and 9 o'clock positions (viewed looking forward); the full length of the engine case had been damaged or distorted by impact. The front fan case was ovalized over a wide area centered about the 4 o'clock position. Markings, such as blue paint smears, rivet witness marks, and red paint transfer on the right side of the engine nose cowl, were consistent with impact forces occurring at the 4 o'clock engine position. The inlet case was found about 30 feet north of the left engine and the nose cowl was 20 feet farther north. The rear fan case was split at the 12:30 to 2 o'clock position; the front flange was crushed rearward at the 4 o'clock position. The upper and lower cowlings were attached to the engine.

The left engine main gearbox had sustained a frontal impact with a right to left direction of the impact force which had partially dislodged the gearbox from the engine. The fuel control unit was separated from the fuel pump and gearbox. The gearbox right mount was shattered, and the right side of the gearbox was badly damaged. The cross shaft was partially dislodged. The linkages associated with the power lever and fuel control shutoff valve were bent and broken precluding an accurate determination of the preimpact positions of those controls.

Most of the first stage fan blades were fractured at the airfoil root. The fracture surfaces revealed no evidence of fatigue. First stage blade tips were rolled over, consistent with the effects of relatively high rotor speed at impact. The second stage blades which remained in the disk were bent opposite the direction of rotation of the disk. Likewise, the fifth stage blades were extensively bent opposite the direction of rotation of the fifth disk. The amount of compressor rotation, which corresponded with blade damage at the time of airplane impact or during engine impact(s), could not be determined from the fan blade damage.

Only five third stage blades remained in the disk. Many of the liberated fan blades were found near the airplane impact point, and others were found near the point where the engine came to rest. The sixth stage blades all revealed evidence of tensile or shear fracture. There were no missing seventh stage blades.

Fragments of aircraft insulating material were observed on the leading edge of some seventh stage blades. Pieces of seat upholstery (seat leather and foam) were found jammed inside a fractured fan inlet guide vane. Three adjacent fan inlet guide vanes had blue paint smears and one vane had white paint smears. These paint smears were consistent with the airplane fuselage color scheme.

In the eighth disk, 29 blade roots remained in their slots; all other blades were liberated. Many outward perforations were observed in the intermediate case rear inner duct in the plane of rotation of the eighth and ninth stage rotors.

Eighth and ninth stage stators were found impacted into the shroud.

Some of the eighth and ninth stage blades exhibited evidence of high stress, low cycle, reverse bending fatigue adjacent to their platforms with multiple origins on the convex and concave airfoil surfaces. These fracture surfaces were typical of the fractures referenced in the Pratt & Whitney JT8D Engine Repair Manual. (See appendix H.) A Pratt and Whitney Product Support Engineer testified that the fractures described in the maintenance manual were a result of improper engine reversing on the ground, which in turn had caused compressor stalls. However, he testified to one exception where such damage was found after a blade root failure. He said that Pratt & Whitney was not aware of any incident where it had occurred secondary to compressor stalls which had occurred in flight. The Pratt and Whitney engineer stated that any engine which was subjected to repeated stalls over an extended period of time, could produce such damage. He testified that in accident investigations, such damage had not previously been found to have occurred secondary to ground impact when an engine had previously been operating at high rpm.

A balled-up, marble-sized piece of titanium alloy, which was identified as an eighth stage blade root, was jammed between two adjacent stator vanes in the 11th stage stator assembly. No other compressor blades exhibited similar deformation. An unidentified airfoil section, which resembled part of a blade from the high pressure compressor, was trapped between the eighth stage stator support rail and a slightly buckled section of the rear skirt. Sharp rotor blade imprints were observed on the trailing edge of the fifth, seventh, and eighth stator assemblies.

The left engine burner can domes, fuel nozzles and transition ducts, and first stage turbine vanes and blades contained titanium-based alloy splatter deposits. The vane airfoils and blades did not exhibit evidence of overtemperature operation.

The left engine examination revealed no evidence of bird ingestion. Neither was there any ingestion of dirt or leaves within the engine. The main fuel shutoff valve for this engine was 80 percent open. The thrust reverser was found in the stowed position.

Cockpit Indications.--The majority of the cockpit instruments, indicators, lightbulbs, and control levers were too badly damaged to reveal meaningful information. A flight director indicator indicated a 60° right bank and a 10° nose-low attitude. The left and right EPR indicators indicated 0.8 and 0.88, respectively. More reliable EPR indications were obtained by examination of the EPR transmitters, revealing gear train positions consistent with 1.35 and 0.95 EPR for the left and right engines, respectively.

The rudder trim knob was intact on a section of the control pedestal and was found in the 1 unit left position. A scratch mark was noted on the indicator scale at a position between 1 unit left and the neutral position. The aileron trim wheel on the same pedestal was in a position of about 1 unit left wing down.

1.13 Medical and Pathological Information

Postmortem examinations of the airplane occupants were conducted by the Medical Examiner of Milwaukee County, Wisconsin. No evidence of disease processes which would have affected the ability of the cockpit crewmembers to operate the airplane were identified. The cause of death of all victims of the crash was reported as "multiple massive injuries to the head, torso and extremities." Tissue samples from the two pilots, one flight attendant, and two passengers were submitted for toxicological testing. However, the tissue samples were contaminated with fuel and other substances, which rendered the results of the toxicological testing meaningless.

1.14 Postcrash Fire and Emergency Response

The wreckage revealed no evidence of in-flight fire. Evidence indicated that any fire associated with the right engine was contained within the engine. N100ME exploded following impact and was largely consumed by the effects of a postcrash fire.

Crash/fire/rescue (CFR) response was effected by the Airport Fire Department, the 440th Air Force Reserve Fire Department, the 128th Air National Guard Fire Department, the Milwaukee County Sheriff's Department, the Oak City Fire and Police Departments, and the Milwaukee County Fire Department. Firefighters witnessing the events immediately preceding the crash began to launch the 440th Air Force Reserve Tactical Airlift Wing Fire Department at 1521 before their official notification. Air traffic control tower personnel notified the Airport Fire Department at 1522, triggering the airport's emergency plan. Response to the crash site was prompt and orderly with the first units onsite and discharging fire extinguishing agent at 1524. There was no difficulty reaching the crash site and sufficient equipment was available to extinguish the postcrash fire. The principal fire area and wreckage had been cooled down by firefighters by 1528.

1.15 Survival Aspects

Impact forces and the postcrash fire destroyed the aircraft, fragmenting the cockpit and cabin and resulting in a nonsurvivable environment. Likewise, the seats were fragmented and showed widespread evidence of omnidirectional loading. Primary loading on the seat legs was to the right.

1.16 Tests and Research

1.16.1 Engine Parts Trajectory Information

The parts which had been ejected in flight from the right engine and which were found on the airport were identified and their locations were plotted on an airport diagram. The identified parts included about 90 percent (by weight) of the failed right engine 9-10 high pressure compressor spacer, thirteen 9th stage and twelve 10th stage compressor rotor blades, part of the compressor stator assembly, compressor vanes, compressor vane shroud, and a small (2- by 2-inch) piece which appeared to be engine cowling. The weight of the nine spacer pieces found adjacent to runway 19R was 2.16 pounds with the largest single spacer piece weighing 1.03 pounds. The weight of the unrecovered 9-10 spacer pieces was about 0.3 pound (the difference between the total weight of an intact P/N 482178 spacer and the weight of the recovered spacer pieces). This would include any material ground away during the rupture and ejection of spacer parts from the engine.

The exit velocity and initial exit angle of ejected engine parts were assumed, based on the tangential velocity, as a result of rotational speed, spacer diameter, position of the hole in the engine, and on Pratt & Whitney experience with other ejected engine parts. Research on types of rotor failure and characteristics of fragments ¹⁹ revealed that when a fragment is ejected from a high speed turbojet engine and passes through an engine casing, it may be deflected from its initial path. However, the research revealed that the deflection causes a loss of energy which is absorbed by the material which deflects the part. The deflection is equally likely to be in an axial or circumferential direction. (See Figure 2.) The author reported that observations of damage to surroundings, which were subjected to uncontained turbine engine parts, show heavy fragments to remain within 5° of the plane of the rotor. (See figure 3.) Greater deflections have been recorded with lighter fragments, but deflections at greater angles than 33° result in the fragments losing virtually all of their energy. The report assumes that in striking the case of an engine, a fragment loses the component of velocity perpendicular to its final line of flight, a decelerating impulse induced

by friction between the fragment and the casing.

Pratt & Whitney representatives testified at the public hearing that their experience had shown that the initial trajectory of uncontained rotating turbojet engine parts may be estimated by assuming that the parts (or fragments thereof) were initially ejected tangentially from their previous plane of rotation, through holes in the case and cowling. This is consistent with the aforementioned research findings. The initial trajectory path may be estimated by aligning a straight object, such as a broomstick, through the hole in the engine case from which the parts were ejected, to the outer diameter of the spacer or rotor that failed (the "broomstick" method). Pratt & Whitney reported that its previous service history of uncontained compressor spacer failures in JT8D-7 and JT8D-1 engines revealed that in incidents where the fuselage was penetrated by ejected spacer pieces, the holes in the fuselage were nearly directly in line with the penetrations of the engine case and tangent to the outer edge of the failed rotating part.

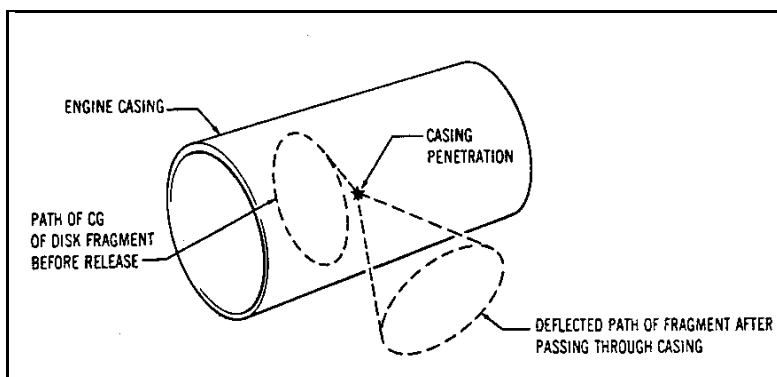

Figure 2.--Deflection path of uncontained engine parts.

Using the broomstick method and relying on the Pratt & Whitney service experience, the initial trajectory of the ejected right engine spacer pieces was determined to be at an angle of about 20° to the right of vertical, away from the fuselage. Based on the calculated climb performance of N100ME (50 feet per second) before the right engine failed, the pitch attitude of the aircraft was determined to be 12° nose-up at the moment of the failure. The engines of the DC-9-14 were mounted to the engine pylons at another 3° nose up. Thus, the ejected engine parts were assumed to have a rearward component, based on the rearward alignment of the engine, 15° nose-up horizontal. A wind factor, based on a wind from 220° at 17 knots, was assumed.

The recovered spacer and compressor blade parts were measured to determine drag reference areas, using a factor of 0.635²⁰ to allow for tumbling of parts. Thus, the drag reference areas for the largest spacer part, weighing 1.03 pounds; a smaller spacer part, weighing 0.07 pound; and a compressor blade piece, weighing 0.035 pound were determined to be 0.138, 0.03, and 0.019 square foot, respectively. A flat plate drag coefficient of 1.0 was assumed. For the purpose of determining potential tangential velocities, initial ejection speeds between 0 and 800 feet per second (fps) were considered. (Pratt & Whitney determined that the rim tangential velocity of the operating high pressure compressor spacer had been 800 fps.)

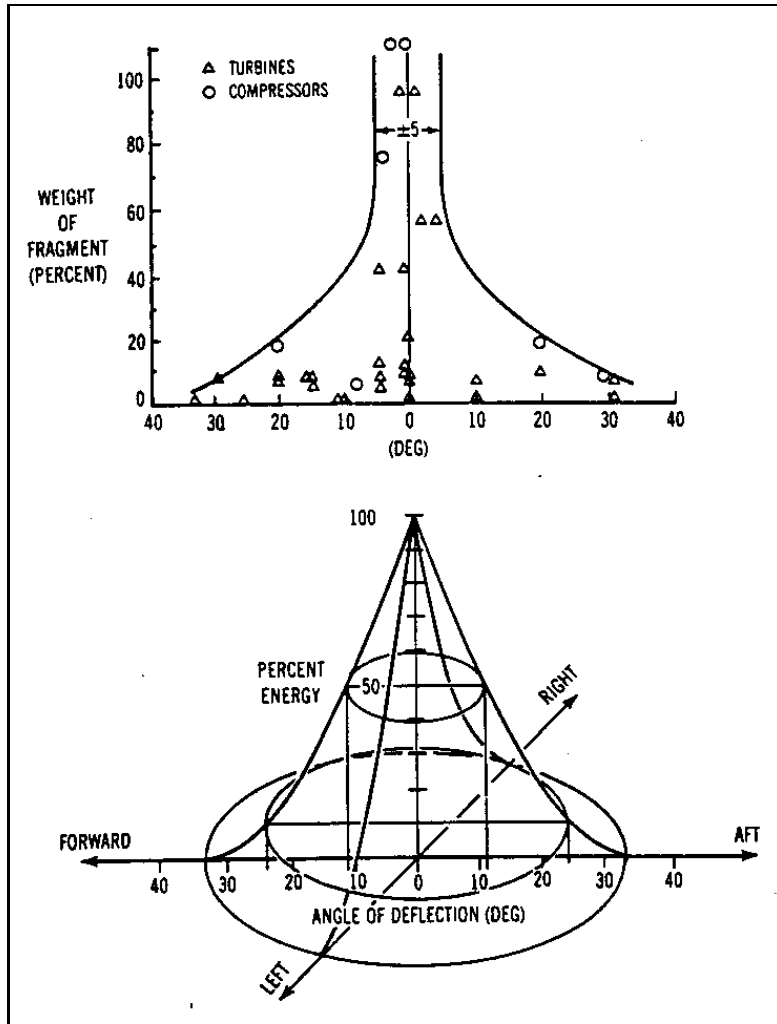

Figure 3.--Dispersion of uncontained engine parts.

The heaviest part would have been most sensitive to the exit velocity and angle. The lighter parts would have been more sensitive to wind factors. It was found that the predicted central point of ground impact would have been about 400 feet rearward and 200 feet left of the aircraft at the time the parts were ejected from the right engine, assuming that the parts were ejected while the airplane was about 450 feet above the ground, left of the runway centerline and at 168 knots. The calculated ejection point was consistent with the point at which parts were determined to have been ejected, based upon the timing of the "clunk" on the CVR tape; the correlation of FDR, CVR, and recorded radar data; and the locations of the recovered engine parts.

The Safety Board explored the possibility that engine parts which were not recovered might have either struck the airplane and been deflected or struck and penetrated the airplane. It was found that exit velocities would have had to be substantially reduced to 60 to 130 fps for fragments to assume trajectories which would allow them to strike the horizontal stabilizer a grazing blow at a 13° to 16° impact angle. Exit velocities required for parts to strike the vertical stabilizer near the rudder hinge line were determined to be in the order of 35 to 70 fps, resulting in an impact angle of 4° to 6°. A Pratt & Whitney engineer testified at the public hearing that his calculations revealed

that if parts were deflected enough to allow them to strike the fuselage, the resultant impact would have had a perpendicular component (into the fuselage skin) of about 10 mph. A consultant for Midwest Express Airlines calculated that, for either the 1-pound spacer part or for a 0.035-pound compressor blade part to have struck the fuselage at 90 fps, it would have been necessary for the parts to have been ejected from the engine with an exit angle 65° left of vertical (85° left of the initial ejection angle).

1.16.2 Containment of Engine Parts

The research also addresses a dilemma related to engine design. That is, to contain fragmenting engine parts, engine casings strong enough to contain the highest energy fragments would be required. This, however, would require a generally unacceptable weight penalty, would create problems of thermal lag in the casings, and would substantially increase the loads on engine mounts.

The research indicates that the energy of a failed engine part, that bulges but does not rupture an engine casing, is transferred to the casing. The addition of the energy from a second part also would be transferred to the case. If the second part struck the same point, additional energy would be absorbed at that part of the case, possibly rupturing the casing. The release of multiple blades (for example) may be assumed to be released singly or in groups and the resultant impacts of those parts against the engine casing may occur almost simultaneously within a small target area. Thus, the containment or noncontainment of engine parts is dependent upon the number, size, and weight of the parts; the relative dimensions of the engine casing; and the rotational velocity of the parts.

1.16.3 JT8D Removable Sleeve Spacers

Removable sleeve high pressure compressor spacers have been used in Pratt & Whitney JT8D engines for more than 20 years. Spacers are installed at six locations within the high pressure compressor of every JT8D engine. The removable sleeve spacer consists of a spacer (similar in shape to a barrel hoop and designed to separate and align compressor disks) and 12 press-fit tubes through which tie-rods pass to align and maintain the integrity of the entire compressor. The 9-10 spacer includes two knife edges, extending from pedestals on the outer circumference of the barrel (or hoop) and which provide a rotating air seal between the spacer and the stationary seal land. (See figure 1.)

Pratt & Whitney service history has shown that rupture of the removable sleeve spacer usually results from cracks which may initiate from stress corrosion, stress alloying, and corrosion pitting of the spacer barrel adjacent to removable sleeves, and from contact between the knife edge and the stator stationary seal land. The most common crack source has been knife edge cracks that propagated through the pedestal and led to failure in the spacer barrel. Pratt & Whitney reports that friction associated with knife edge rubbing produces heat that initiates fatigue cracks in the knife edge. Many of the knife edge crack-initiated ruptures have been attributed to inadequate inspection or repair during compressor module overhaul. All of the uncontained spacer failures to date have reportedly involved the removable sleeve design.

Pratt & Whitney records revealed that 45 removable sleeve spacers had failed in JT8D engines before the September 6, 1985, Midwest Express accident. Twenty-six of the incidents resulted in the in-flight shutdown of the affected engine, and 7 incidents resulted in penetration of the cowling by ejected spacer parts. Five of the incidents which involved cowl penetration also resulted in spacer parts penetrating the fuselage. Only one case where spacer parts penetrated the fuselage involved a DC-9 airplane. Two additional failures occurred in a Pratt & Whitney test cell. None of the previous incidents resulted in loss of an aircraft or caused any injury.

In early 1980, Pratt & Whitney conducted cyclic spin testing of a 7-8 stage spacer from a JT8D engine to generate

data on knife edge crack propagation rates in high pressure compressor spacers. The test was conducted at a temperature of 540°F, approximately the normal operating temperature of the spacer. The spacer was subjected to stress by repeatedly cycling from 1,000 to 12,600 rpm to simulate engine stress cycles. ²¹ Four saw cuts with depths of 0.011, 0.071, 0.135, and 0.297 inch were made in the knife edge and pedestal so that propagation rates for different crack lengths could be generated simultaneously. The spacer was subjected to a total of 5,000 test cycles. Data collected from the test allowed Pratt & Whitney to study the nature of crack propagation from knife edge initiation and to predict cycles from crack to rupture in other spacers.

The cyclic spin test disclosed that a 0.010-inch long (10-mil) crack in the knife edge would typically propagate through the knife edge to the top of the pedestal (which supports the knife edge) in about 13,000 cycles. The data showed that the crack typically would progress through the cylinder wall in an additional 7,000 cycles, and then would progress axially until rupture of the spacer barrel in about 1,000 additional cycles. Thus, such a crack would progress from a 10-mil length in the knife edge to rupture of the spacer in about 21,000 cycles. According to Pratt & Whitney, before rupture, the spacer barrel may deflect into the stator seal land and frequently results in abrading away the knife edge and removing the original crack. The ruptured spacer then separates into segments, which may exit the engine.

The cyclic spin test indicated that a 10-mil crack originating in the cylinder wall typically required 25,000 cycles to become a cylinder-through-crack, and then another 1,000 cycles to rupture. (Pratt & Whitney cyclic spin test results are shown in figure 4.) In each example, a 10-mil crack was assumed as the initiating crack length.

Pratt & Whitney reported that the growth of spacer knife-edge cracks is retarded when the cracks begin to propagate into larger cross sections. The spin test showed that about 3,000 cycles are needed to propagate a knife-edge crack from the thin knife edge to the thicker pedestal section of a compressor spacer.

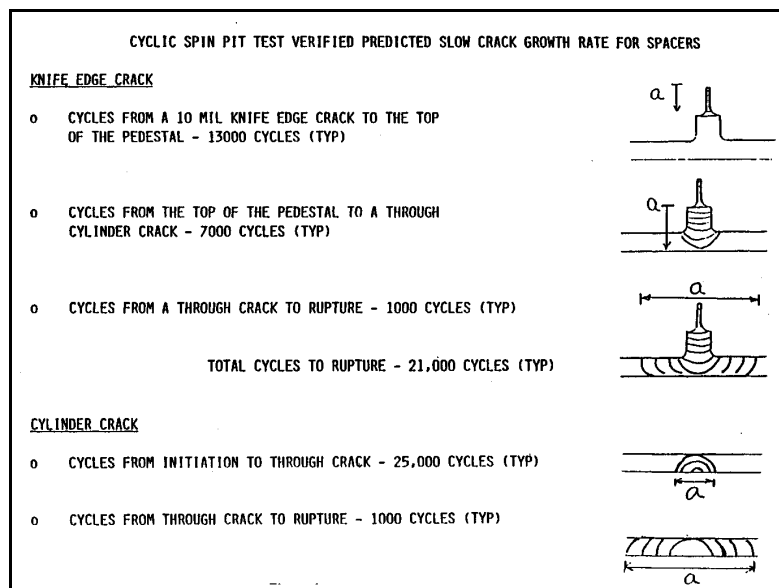

Figure 4.--Cyclic spin test results.

Based upon an analytical model developed from the 1980 cyclic spin pit data, Pratt & Whitney concluded that, at approximately 3,000 test cycles before (imminent) rupture of a 7-8 stage spacer, a fatigue crack initiating in a knife edge would have extended to a length of at least 0.20 inch. A crack of this size would extend through the knife

edge and into the pedestal in either the 7-8 or 9-10 stage spacer. Pratt & Whitney calculated a crack growth rate equation for a 9-10 stage spacer based on the 7-8 stage data and the known differences in operating temperatures and stress. The calculation indicated that a knife edge crack would be 0.33 inch in length about 3,000 (test) cycles before rupture of the 9-10 stage spacer.

Minimum crack length detection limits are dependent on operator technique and experience, the condition of the inspection equipment and other variables. During the cyclic spin test, crack extensions of 0.040 to 0.045 inch were detected using fluorescent magnetic particle inspection (FMPI). Pratt & Whitney recently gathered unrelated field data (from airlines and repair stations) on FMPI of bolt hole cracks in 10th stage disks which were composed of the same material as the spacer. These data also indicated that cracks 0.045 inch in length within the bolt holes could be detected using FMPI techniques.

1.16.4 Metallurgical Examination of Aircraft Parts

Nine pieces of the right engine 9-10 spacer, pieces of the aft fuselage and empennage skin, broken left engine eighth and ninth stage compressor blades, control cables, and the rudder pedals were examined at the Safety Board's Materials Laboratory.

Right Engine - 9-10 High Pressure Compressor Spacer.--All of the spacer pieces were heavily deformed and contained areas of rust-colored oxidation products as a result of exposure to the environment after release from the engine. The corrosion was heaviest on the inside diameter of the barrel of the spacer.

Many of the spacer piece fracture surfaces were obliterated by secondary damage. Those fracture areas not damaged were, with one exception, typical of overstress separations. The one fracture area which did not appear to be an overstress separation was found on one end of the largest spacer piece. It was on a flat axial plane through the rear knife-edge pedestal and a portion of the adjacent barrel. Near the fracture, heavy rotational wear had completely eroded the forward knife edge and pedestal, had progressed completely through the barrel between the pedestals, and had eroded a portion of the rear pedestal. Heavy corrosion deposits, which extensive cleaning could not totally remove, were found on the flat axial fracture area. However, there was a gently arcing boundary between the flat axial fracture area and a shear lip region adjacent to the inside diameter of the barrel. The flat plane of cracking in the flat axial zone and the gently arcing boundary were consistent with progressive cracking which initiated in the rear knife edge or pedestal and progressed inboard. A metallographic section through the flat axial zone revealed no evidence of branching cracks, such as those associated with liquid metal embrittlement.

Numerous small circumferentially aligned cracks were noted in various spacer pieces in the barrel, between bleed air holes. A metallographic section through one area with a significant number of these cracks revealed that some cracks were filled with nickel. Nickel and cadmium are used to plate the parts during rework to prevent corrosion.

In many areas on the spacer, the snap surface nickel cadmium layers had debonded the underlying steel. The debonded areas could easily be extended by pulling on the already free portion of the nickel cadmium layers. A very small amount of cadmium was detected in the freshly debonded areas. No defects were found on metallographic sections through the snap surface areas which were not debonded.

Aft Fuselage and Tail Damage.--Damaged areas of skin were examined to determine whether the damage was produced by ejected right engine components. One damaged area in the vertical stabilizer had been penetrated from the inside, toward the outside of the stabilizer, indicating post-impact damage; thus, no further work was warranted on this sample. Of the remaining samples, each contained a scrape mark and some contained skin penetrations, although there was no evidence that parts had passed through the skin and entered the airplane. All of the scrape marks were consistent with an object striking at a very shallow angle to the surface of the skin and were approximately aligned horizontally in the direction of airplane motion or air flow. Trace amounts of cadmium were

detected in several scrape areas; however, no evidence of nickel was found.

Tests were conducted to determine the type of metal transfer which might occur when a spacer part contacted the aluminum alloy airframe structure. Skin sections were struck against sharp 90° exterior corners of a 8-9 stage spacer section. Analysis of the contact areas revealed the presence of a significant amount of cadmium (from the nickel/cadmium surface layer on the spacer). Only a very small amount of nickel was transferred to the skin surface. The tests did not conclusively determine whether a spacer part impacting a skin area at a shallow angle, would leave behind traces of cadmium without leaving behind traces of nickel.

Therefore, the Safety Board could not determine from the metallurgical examination whether spacer parts had produced any of the observed airframe damage.

Left Engine - Eighth and Ninth Stage Compressor Blades.--Examination of broken eighth and ninth stage compressor blades revealed that many blades contained high stress fatigue cracking features over much of the fracture area. In all cases, there was evidence that fatigue cracks initiated near the blade root, from multiple origins on both the concave and convex sides of the blade airfoil section. No evidence of a preexisting defect was found in the initiation areas.

Control Cables.--The control cables from the rear of the aircraft were examined for evidence of ground impact damage or metal transfer associated with nickel cadmium-plated parts. Many of the fracture surfaces had been damaged but only one damage area contained traces of cadmium. However, the amount of cadmium was insufficient to allow the Safety Board to conclude that the cable had been struck by a cadmium-plated component because exposure of the cables to ground fire could have deposited residue with cadmium concentrations comparable to that found.

Rudder Pedals.--Because of a previous history²² of rudder pedal support arm failures, the Safety Board examined the rudder pedal assemblies in its Materials Laboratory. The examination revealed that all portions of the rudder pedal assemblies had been subjected to heavy fire damage. Even after cleaning, the fracture areas on the captain's and the first officer's left rudder pedal support arms were partially obscured by heavy corrosion deposits and fire residue. The fractures were rough in texture, similar in appearance and had occurred at virtually the same location on the assemblies. Although no evidence of fatigue cracking was discernable, the fracture mode of the pedal support arms could not be positively determined.

1.16.5 Aircraft Performance Calculations

At the request of the Safety Board, Douglas Aircraft Company calculated the takeoff and climb performance of N100ME. The calculations were based on two engine climb performance to 1,130 feet m.s.l., followed by the loss of one engine and continued climb with varying degrees of thrust loss on the remaining engine. (The thrust loss from the second engine was indicated in the CVR sound spectrum examination.) The calculations revealed that if takeoff thrust had been 11,000 pounds (per engine), a loss of about 4,000 pounds thrust from the remaining (left) engine eventually would result in the pilot being unable to maintain level flight, although control of the aircraft could still be maintained. These calculations did not assume any sideslip as a result of the initiating engine failure.

The calculated initial performance of N100ME was consistent with a normal two-engine operation of a DC-9-14 airplane. The actual liftoff was determined to have occurred about 1.6 seconds beyond the optimum performance liftoff point. The calculated gear-up, stabilized two-engine climb rate was consistent with a 12° pitch attitude. Climb rate 4 seconds after the right engine failed was compatible with a normal transition to a single engine operation.

Several representative ground tracks were developed from a DC-9 aerodynamic model using equations of force,

moment, and motion similar to those used in simulator models. The tracks were not representative of the result of all possible control inputs but were useful in arriving at a rough flight profile of the accident airplane. Comparison of the tracks with the radar and FDR profile of the flight provided an indication that right rudder may have been required to produce the rate of heading change which was documented by the FDR.

The Safety Board used FDR airspeed data to calculate the distance traveled. The FDR-indicated airspeed was corrected for sideslip by subtracting the airspeed error, which was determined to be zero at FDR time 00:54 (1/2 second after the engine failure) and 14 knots starting at 00:59. Corrected airspeed was then converted to true airspeed to which a wind component of 13 knots (at the runway) to 16 knots (at altitude) was applied to determine groundspeed. Groundspeed was integrated to yield distance traveled. (See appendix F.) The 14-knot error was applicable until 1:09 FDR time, which was the end of the CVR tape and the time of impact.

1.16.6 Flight Demonstration

Safety Board investigators interviewed DC-9 pilots regarding the single engine flight characteristics of the DC-9-14 airplane. McDonnell-Douglas pilots stated that the airplane had no unusual handling characteristics and that it did not require "exceptional pilot skill" during single engine flight, even with the yaw damper disengaged. They testified that the airplane was easily controllable (with control wheel input) after a sudden loss of thrust from one engine, even without the use of rudder to compensate for yawing of the aircraft. Other pilots, however, advised the Safety Board that the DC-9 was a "rudder airplane" and that prompt and correct rudder deflection was necessary for recovery from the loss of thrust, following an engine failure, particularly just after takeoff. Some pilots also advised the Safety Board that the DC-9 had unstable (undamped) yawing motion with the yaw damper off, contrary to the McDonnell-Douglas testimony.

The Safety Board learned that the available wind tunnel and flight test data were not sufficient to define the lateral dynamic response of the airplane following the sudden loss of thrust from one engine at takeoff speeds. To resolve the questions, the Safety Board conducted a flight demonstration using an FAA DC-9-14 airplane on June 11, 1986. The airplane was operated by FAA and McDonnell-Douglas test pilots who were qualified in the DC-9. Three separate procedures were used to duplicate a loss of thrust from the right engine:

1. Slowly reducing thrust by retarding throttle and compensating for yaw with appropriate rudder deflection. (At steady flight, the rudder was quickly returned to neutral.);
2. A rapid throttle chop beginning at takeoff power (with no rudder input to correct for yaw);
and
3. Reduction of thrust by shutting off the fuel flow at takeoff power (with no rudder correction).

In each test, takeoff power was maintained on the left engine. The maneuvers were performed with the landing gear up, with 20° flaps, and at speeds consistent with the Midwest Express flight profile. The plan was to demonstrate a sequence of flight conditions which were considered progressively more severe. The initial demonstrations were performed at about 10,000 feet m.s.l. to allow an appropriate safety margin. Later demonstrations were conducted at about 5,000 feet to allow a greater thrust differential, more closely duplicating portions of the accident flight after it had been demonstrated (at 10,000 feet) that the airplane handling was docile. The pilots used preplanned flight test cards which outlined procedures which were practiced in the same Republic Airlines DC-9-10 visual flight simulator that was used to train the Midwest Express pilots. The flight was documented with the CVR, FDR, and a high quality audio recorder (for engine sounds) and a videotape (cockpit instruments). Rudder and control wheel deflection also were measured. Because of the docile nature of the airplane during the initial tests, only 7 of the 11 planned demonstrations were necessary to obtain meaningful data.

In the first set of demonstrations, during yawing motion (which resulted from engine-out operation), indicated altitude rose about 50 feet and the indicated airspeed rose about 3 knots. A corresponding 8° to 9° left rudder deflection was required to offset the asymmetrical thrust condition which caused the sideslip. A 25° to 30° left wheel deflection (aileron input) was required to maintain a near-wings-level attitude with the rudder neutral, although slightly greater deflections were used as the roll rate was initially arrested. (Full control wheel deflection is in excess of 90°. Full rudder deflection is about 37° at speeds below 176 knots.)

The throttle "chop" demonstrations resulted in a final yaw angle of 7° to 9° attained in about 4 seconds with the yaw damper off. With the yaw damper on, the yaw angle was reduced slightly. The engine pressure ratio had decreased to its lowest level in about 1 to 1 1/2 seconds. About 30° of control wheel deflection was required to maintain neutral roll attitude (with rudder neutral) after the throttle chop. There were no significant differences between the throttle chop demonstrations and fuel cut demonstrations.

In one series of demonstrations, the airplane's response to the absence of both aileron and rudder control input (following a simulated engine failure) was documented. With the rudder damper on or off, a 30° roll angle was reached in 7 to 8 seconds. When the pilot pushed forward slightly on the control yoke, the pitch angle dropped from 15° nose up to 10° nose down. With no control yoke movement by the pilot, the pitch attitude changed from 10° up to about 5° downward. Recovery required 90° of control wheel input for 1 second in the first case and for 3 seconds in the latter.

The results of the flight demonstration showed that at 170 knots and with the loss of thrust from the right engine:

1. The airplane was easily controllable without the use of rudder deflection;
2. The yaw damper had little effect on the airplane motion and was not essential for recovery;
3. At greater thrust levels, the airplane incurred a heading change of 8° to 10° in 3 to 4 seconds; and
4. Static pressure error due to sideslip was demonstrated and was consistent with the static pressure error data provided by the Douglas Aircraft Company.

The flight demonstration pilots reported that the airplane performance in all of the demonstrations was docile and easily controllable after a sudden loss of right engine thrust at 170 knots, even without rudder input or yaw damper action. The airplane performance, which was documented by the flight demonstration, was consistent in all respects with the applicable certification standards.

1.17 Additional Information

1.17.1 Approval and Surveillance of Midwest Express Pilot Training

The FAA's Flight Standard District Office (FSDO) 61, in Milwaukee, Wisconsin, had primary certification and surveillance responsibility for Midwest Express Airlines. As of July 1985, FSDO 61 held 52 air carrier certificates, including 3 FAR 121 operators and 49 FAR 135 operators. Also, the FSDO had surveillance responsibility for schools and repair stations, and other general aviation activities. The Principal Operations Inspector (POI), who was assigned to Midwest Express Airlines, also was responsible for two other FAR 121 certificate holders, Midstate Airlines and Basler Flight Service, but she was not responsible for any other air carrier certificate holders. Because the POI previously had served as a general aviation operations inspector (Aviation Safety Inspector, Operations),

she also conducted general aviation flight checks and stood accident standby duty. She estimated that, in a recent 6-month period, she had spent about 20 percent of her time dealing with her Midwest Express responsibilities. The POI testified that she had no experience piloting jet aircraft and that she had received no formal training on the DC-9. She said she had about 7,000 hours of pilot experience, which was acquired in general aviation aircraft. The POI held Airline Transport Pilot and Flight Instructor certificates. She held a type-rating in the turboprop Shorts SD-3-30 Skyvan. She joined the FAA in May 1976 and became an air carrier POI in 1984. She attended an air carrier indoctrination course in 1983 and a POI training course in August 1984.

The POI testified that it was not unusual for a POI to have certification and surveillance responsibility over an air carrier operating aircraft in which the POI was not qualified. However, she reported that she was not totally comfortable with the situation. She was responsible for the initial approval of all Midwest Express operational procedures and manuals and the pilot training program. To accomplish this task, she relied on FAA DC-9 rated inspectors in neighboring FAA offices to review proposed Midwest Express procedures and manuals. The POI stated that she had received verbal assurances that the manuals met FAA requirements from inspectors in those offices, and that based on those assurances, she approved the procedures and manuals. There were no inspectors in the Milwaukee FSDO who were qualified in the DC-9.

The approval of the training program, which was to utilize Republic Airlines instructors and facilities in Atlanta and a Republic Airlines DC-9-10 series flight simulator, required that the POI also approve the use of the Republic Airlines flight simulator. Because the POI had very limited exposure to flight simulators and no DC-9 training to effectively evaluate the suitability of the simulator, she relied on the Republic Airlines POI and, based upon his advice and a review of the curriculum, she approved the use of the simulator. It was not a requirement that the POI be qualified on or have special training in flight simulators in order to be responsible for approving the use of the simulator. She determined that the training curriculum met all FAA requirements and as a result, gave initial approval to the training program in April 1984. The POI said that she gave final approval to the training program after the actual training was monitored by an FAA inspector qualified in the DC-9.

The POI testified that she did not personally observe the Midwest Express pilot training before giving final approval to the program. Subsequently, she said she observed some initial, upgrade, recurrent, and emergency training in the flight simulator. She estimated that she had observed training in the simulator "once every 2 months, or so." She reported that she had not observed any training or checking in the DC-9 airplane.

At the Safety Board's public hearing, the POI demonstrated uncertainty of some Midwest Express DC-9 operating procedures. When asked how crew coordination could be taught and practiced in the airplane, she stated that the Flight Operations Manual contained a general statement on the subject. When asked whether emergency checklist callouts, such as "Max Power," "Ignition Override," and "Check Fuel System" should be made after an engine failure on takeoff (at 450 feet a.g.l.), the POI stated that she would like to hear such call outs, but was not sure that they were required. The POI did not think that a DC-9 pilot should be expected to verbalize "Engine Failure" if the failure occurred at that point in the takeoff. When asked to comment on the statement in the COM, "Any crew member noting a potential or actual emergency situation will call it to the captain's attention," the POI indicated that the statement should not necessarily be applied to the cited takeoff situation, a distinction which is not found in the COM or Flight Operations Manual. The POI said she had never seen anything in writing about a "silent cockpit" philosophy²³ after takeoff, but in principle did not object to the idea. She stated that she had not approved the concept.

The POI was asked by Midwest Express to reduce the 40-hour indoctrination period in pilot training to 32 hours, because the instructors were intimately familiar with the course material. She approved the request. The training curricula was also reduced in other areas because of the experience and expertise of the instructors, and quality of training aids which would be used at the Republic Airlines Training Center. When Midwest Express advised the POI that the first officer on flight 105 had received the necessary ground training for check airman and requested

that he be evaluated as a check airman, she arranged to observe him conduct a proficiency check, and then qualified him as a check airman without checking his training records. The POI learned after the accident that training records did not reflect that the first officer had completed all of the required training. She stated that she had never turned down a Midwest Express request for program changes, and that she had not filed any violation action against any Midwest Express pilots.

The POI performed an en route check of the two pilots of flight 105 on September 5, 1985. No discrepancies were noted by the POI on that en route check, nor were any discrepancies noted on the other FAA en route checks involving those pilots.

1.17.2 Training at Republic Airlines

Republic Airlines, Inc., had contractually agreed to provide Midwest Express pilots DC-9-10 ground school, cockpit procedures training, and simulator and airplane flight training. The decision to utilize the Republic Airlines training facility and personnel in the training of Midwest Express pilots was based, in part, on the small size of Midwest Express, which operated only 3 airplanes and employed about 25 pilots, including its director of operations, chief pilot, 2 flight managers, and several check airmen who were not full-time line pilots. As Midwest Express pilots upgraded their qualifications with line check and recurrent proficiency check authorizations, Republic's instructor personnel were eventually replaced in the simulator and flight training programs. However, the majority of the Midwest Express DC-9 training provided to the pilots of flight 105, particularly on abnormal and emergency procedures, was administered by Republic instructors in the Republic DC-9-10 visual flight simulator located in Atlanta, Georgia. The captain received his initial and captain upgrade training from Republic. The first officer received captain and check airman training at Republic after previously receiving initial DC-9 training at USAir as an employee of K-C Aviation, the parent corporation of Midwest Express Airlines. The check airman curriculum included training on appropriate safety measures to be taken from either pilot seat in emergency situations which might occur in training, including the potential results of improper or untimely safety measures.

The Republic Airlines instructor, who provided much of the ground, simulator and flight instruction to both pilots, said he had not encountered any problems with either of them. He reported that in a typical simulator training session, he gave perhaps three or four simulated engine failures associated with takeoff where at least one occurred after V1, when a decision to continue the takeoff was warranted. He said that he emphasized flying the airplane first (maintain control) and then dealing with the problem, followed by communicating with air traffic control when time permitted. He also said he discussed with students the indications of powerplant failure and that initial detection of the failure would most likely come from yawing of the airplane.

According to the Republic Airlines instructor, a common mistake among pilots new to the DC-9 is to make improper rudder corrections after a simulated engine failure and to put too much reliance on aileron control (which could cause a dutch roll). He said that he emphasized correcting the yaw with rudder first, and then applying aileron as needed. He commented that a student in the DC-9 visual flight simulator had to be sharp to detect the yaw change because the yaw motion cue was not present in the simulator. He said he taught that detection of the yaw could be aided by outside or inside visual cues. For example, during a typical V1 engine cut in the simulator, the outside visual display would include runway centerline lights which would provide a visual cue aiding the pilot in detecting and correcting for yaw.

The training at Republic Airlines did not specifically address uncontained engine failures or compound emergencies not resulting from engine failure. The training included a discussion of keeping cockpit conversation to a minimum after reaching 100 knots on takeoff. The instructor said that, based on the training he provided, he did not believe any communication, including identification of the engine failure or making emergency checklist callouts, was required after the right engine failure, until reaching 800 feet a.g.l. on the accident flight. He added that, if airspeed

had been a problem, however, he would have expected a callout for "Maximum Power," which is one of the items on the emergency checklist.

1.17.3 Emergency Procedures, Engine Failure After V1 (Takeoff Continued)

The Emergency Procedures section of the Midwest Express COM provides standard operating procedures to follow in emergency situations. The COM emphasizes that pilots should carefully perform the procedures to minimize error and that "crew coordination is essential" in responding to emergencies. The COM reminds pilots that, during an emergency, special care must be taken to "continue flying the aircraft in compliance with ... good flight operating practices." The COM states that normally the captain will initiate an emergency procedure; however, "any crewmember noting a potential or actual emergency situation will call it to the captain's attention." All pilot crewmembers are required to be prepared to handle the emergency duties of other pilot crewmembers.

The COM calls for the following actions if an engine failure occurs after V1:

- The pilot calls "max power," and with a positive rate of climb on the altimeter, the copilot calls "positive rate";
- The pilot will call "gear up--ignition override--check fuel system";
- The copilot then performs these actions;
- The pilot then climbs at V2 until reaching 800 feet or MGLO, ²⁴ whichever is higher;
- The pilot then accelerates to V2 + 20 knots (for a 20-degree flap takeoff), retracts the flaps, and continues accelerating to en route climb speed; and
- The engine fire/failure checklist can then be performed.

Both the Midwest Express COM and Training Manual remind pilots that "on all engine-out maneuvers, be alert on the rudder and keep the ball nearly centered [i.e., heading constant]. Rudder trim shall normally be used after clean up."

Douglas Aircraft Company recommends that when an engine fails after the takeoff decision speed (V1), the pilot should call out "ignition override," indicating to the copilot that an engine failure has been identified. The copilot normally monitors the instruments and calls out any malfunctions to the pilot. If an engine fails after V1 and the pilot does not call for "ignition override," Douglas recommends that the copilot should call out "engine failure" upon observing an indicated malfunction on the engine instruments. Douglas teaches this philosophy to ensure that the crewmembers coordinate activities during a critical phase of flight and that they accomplish the only task necessary to the engine operation at that time; namely, switching to "ignition override."

Douglas teaches pilots that keeping control of the aircraft is paramount. This effort includes maintaining wings level (with enough rudder control input to counteract the asymmetric thrust condition) and constant heading. The climb is continued and "gear-up" is called after the "positive rate" call by the copilot. Airspeed of at least V2 is maintained (single-engine climb speed) until the aircraft is clear of obstacles or until the acceleration height is reached, at which time the aircraft levels off. The flaps are retracted on the appropriate schedule and the aircraft continues accelerating to the single-engine en route climb speed or a minimum of 1.5Vs (50 percent above the stall speed) if it remains in the local area. The engine failure checklist is then performed per the Douglas Flight COM.

At the Safety Board's public hearing, the Midwest Express chief pilot and a Republic Airlines flight instructor, who had instructed Midwest Express pilots, testified that Midwest Express pilots were taught in training, per company policy, not to make unnecessary verbal comments, including identifying or describing the nature of an emergency occurring on takeoff, during the interval between the attaining of 100 knots on takeoff roll until reaching 800 feet or MGLO altitude. The Midwest Express chief pilot stated a concern that such communication as identification of a failed engine during that interval constituted unnecessary communication which might distract or mislead the pilot who was flying the aircraft (particularly if the emergency was misidentified). The Republic Airlines instructor stated that even the emergency callouts of "Max Power," "Ignition Override," and "Check Fuel System" should not be made if an engine failure occurred on takeoff after gear retraction and before reaching 800 feet or MGLO. The Midwest Express chief pilot explained that his company viewed the takeoff emergency as one that could be dealt with according to the criticality of the precise phase of flight.

Because the interval from V1 to gear retraction was considered most critical, no latitude with regard to interpretation of emergency procedures was allowed during that phase of the takeoff. The chief pilot stated that after gear retraction the reduced criticality of the situation allowed the crew the luxury of delaying any action other than flying the aircraft safely to 800 feet or MGLO, at which time the crew could discuss the situation and take appropriate action. This variation in how to respond to engine failure on takeoff emergencies was also expressed by the Republic Airlines flight instructor.

Both the Midwest Express chief pilot and the Republic Airlines instructor testified that they would not have expected the crew of flight 105 to have made any emergency callouts before reaching 800 feet or MGLO, in accordance with the "silent cockpit" philosophy. The Republic Airlines instructor said his company does not put as much emphasis on this subject as Midwest Express but limits communication to the essential during critical phases of flight.

A policy consistent with such training was not stated in the Midwest Express DC-9 Flight Operations Manual, the COM, or the Training Manual. However, the COM states:

During an emergency condition, non-essential conversation will be kept to a minimum. This ensures the Captain's commands are heard and will eliminate any needless distractions which may interfere with flying the aircraft and executing procedures. ATC notification and communication should be accomplished only after the emergency is under control.

The Flight Operations Manual states that all crewmembers are responsible for bringing to the attention of the other crewmembers, particularly the pilot-in-command, any condition, occurrence or malfunction which may affect the safety of the flight. It states:

Crewmembers shall never assume that other crewmembers are also aware of such matters without verification.

Midwest Express Airlines holds its captains responsible for making all necessary decisions in response to in-flight emergency situations. The captain will designate the person responsible for flying the aircraft. A check airman, who is assigned first officer responsibilities on a flight, shall perform first officer duties and does not have the authority to assume control of the flight, barring extreme circumstances. Nonetheless, in a formal submission of their views regarding the accident, Midwest Express Airlines stated that the first officer, who was also a DC-9 check airman, would have taken over if he thought he could have improved the situation. There was no indication on the CVR that the first officer responded to the emergency or assumed control of the flight.

1.17.4 DC-9 Flight Simulator Training

Flight Simulator Developments and Limitations.--In the last 25 years, significant advances in flight simulator

technology have allowed the development of a series of modern flight simulators which can be used as alternatives to the training and checking of pilots and flight engineers in air carrier aircraft. In fact, the FAA reports that most turbojet air carrier training and checking are now performed in flight simulators, even though some simulator training is supplemented by training in the aircraft. Today, the most advanced (FAA-qualified) flight simulators accommodate all pilot training and checking requirements. Some training is performed in aircraft at the option of the carrier; in some cases it is performed because FAA credits for certain maneuvers are not authorized in the available flight simulators. Among the flight check maneuvers that are permitted to be performed in visual simulators (in lieu of flight checks in the airplane) are engine failures at V1. Maneuvers which involve landings are not allowed for credit in visual simulators, but are permitted in the more advanced flight simulators.

The responsibility for qualifying a simulator for such training rests with the FAA National Simulator Evaluation Team (NSET), which is composed of technical staff and aviation safety inspectors (pilots) who have had specialized training in the operation of flight simulators. When an air carrier acquires or upgrades a flight simulator for use in training, NSET is obligated to examine and qualify the simulator before it can be used for training. NSET then advises the FAA POI with regard to capability of the referenced simulator. The POI has the option of approving or rejecting the use of the simulator based upon the overall training program needs and the capability of the flight simulator. For example, the flight simulator used to train the pilots of flight 105 was qualified, then periodically inspected and re-evaluated by NSET at 120-day intervals. The simulator was maintained by its owner/operator, Republic Airlines.

The capability of flight simulators to provide motion cues, from which pilots learn to recognize and react to in-flight situations, can be generally divided into two groups: those simulators having 3 degrees of freedom (dof) motion cues and those having 6 dof. The first three motions are pitch, roll, and heave (a vertical motion). Nonvisual, visual, and Phase I flight simulators normally have 3 dof (unless they are being upgraded to 6 dof for eventual qualification as Phase II simulators). Phases II and III (advanced) flight simulators add lateral motion, yaw motion, and fore-aft (longitudinal) motion.

The primary differences between the motion cues provided by 3 dof and 6 dof systems are in the "onset" motion cues. The long term motion cues are almost identical. For example, the long-term motion cue that would represent a lateral acceleration is obtained by rolling the simulator (for both 3 dof and 6 dof) resulting in the occupant sliding sideways, as if experiencing a lateral acceleration. The 6 dof system accurately duplicates the "onset" of acceleration by actually accelerating the occupant sideways. The 3 dof system cannot do this. It can only roll abruptly, which when coordinated with the visual and instrument cues can "fool" the pilot into sensing a lateral motion. Although this method does not precisely duplicate the onset of acceleration, it does provide useful cues.

Aircraft provide kinesthetic, sound, and peripheral visual cues which are not available in the visual simulator. Because of the lack of onset motion cues, training in a flight simulator which has only 3 dof is somewhat less realistic than training conducted in a 6 dof simulator or in the aircraft.

Despite limitations in the ability of simulators to fully replicate the airplane, simulators have received acceptance for air carrier training because of economic (fuel and other airplane operating costs) and safety considerations. Training in the simulator also can be more effective than training received in the airplane because training maneuvers can be stopped, discussed, and repeated in the simulator and because maneuvers may be safely experienced in the simulator that cannot be safely practiced in flight. Wind shear training, for example, could be very effectively taught in a simulator but would not be demonstrated or practiced in the airplane due to practical as well as safety considerations.

DC-9-10 series airplane operators, if they wish to use a DC-9-10 series simulator, must obtain their simulator training in 3 dof visual simulators because advanced (6 dof) simulators are not available for that series DC-9. This results in a requirement that landing credits, which cannot be obtained in the simulator, must be acquired in the

airplane. However, the practicing of engine failure maneuvers on takeoff, are authorized in the visual flight simulator.

Training Value of Motion Cues in Flight Simulators.--Witnesses at the public hearing differed regarding the effectiveness of the 3 dof visual simulator in teaching recognition and response to an engine failure on takeoff. Pilots at the hearing testified that the DC-9 simulator training was effective, even if some onset motion cues were not present in the simulator. They believed that a pilot's reaction to an engine failure on takeoff was fundamental and should not require an abundance of cues. Two FAA flight simulator experts stated that they believed that the 3 dof visual simulator training was effective. They also stated that they believed that the time required for a pilot to react to a loss of engine power on takeoff in the airplane would not be significantly altered, if altered at all, when a pilot's only previous exposure to such an emergency was in the 3 dof simulator.

However, a human performance expert in the area of flight simulation, testified that motion cues, which were not present in 3 dof flight simulators, were important in recognizing and reacting to an engine failure in an airplane after takeoff. He said pilots react quickly to kinesthetic or acceleration motion cues (vestibular cues which were missing in the simulator) because they provide a more immediate indication and, therefore, are more relevant alerting cues than are visual cues. He reported that his experience had shown that, to be effective, simulator motion cues should match as accurately as possible the motion cues of an airplane.

He reported that the DC-9-10 visual simulator did not accurately reproduce all the motion cues that would be available in the airplane because of the absence of yaw (from differential thrust) and deceleration cues. He suggested that if the flight 105 pilots encountered these cues in the airplane, not having been exposed to them previously in training, they might have become confused and uncertain, affecting their ability to recognize and respond to the emergency. He suggested that to resolve the confusion and uncertainty the pilots might have exercised the controls, possibly reacting incorrectly to the problem.

The Safety Board reviewed an extensive body of behavioral science literature regarding the value of high fidelity motion cues in simulators in providing effective pilot training. The literature was not consistent in this regard. Some studies ²⁵ present persuasive arguments to support the conclusion that high fidelity motion cues are essential to training for abnormal occurrences such as engine failures. However, other studies indicated that high fidelity motion cues were not necessary for effective pilot training. The authors of a recent study ²⁶ reported that no data existed which would show that high fidelity motion cues were necessary for civil transport operations. They reported that training transfer studies conducted on general aviation and military flight simulators did not support the assertion that high fidelity motion cues were essential. The authors described a study in which Boeing 727 qualified pilots were used to evaluate the effectiveness of a 6 dof Boeing 727-200 simulator. During the test, the 6 dof simulator was reduced at times to 2 dof (unbeknownst to the pilots). The response of the pilots to various scenarios, including an engine-out on takeoff which was simulated about 5 seconds after liftoff, was evaluated. At the conclusion of the study, the pilots reported that the simulator fidelity to the airplane was very good in all of the motion platform conditions. The pilot rudder control activity, in response to the engine failure, was not found to be significantly different for the three motion conditions evaluated. The authors reported that the dynamics of the vehicle being simulated, pilot experience in the vehicle and the simulator, and pilot pre-test attitudes and beliefs were all factors which may have affected the test results. However, based upon the conditions sampled, the authors concluded that complex (6 dof) motion platforms may not be necessary, and that limited motion capability of the simulator may be adequate for training purposes in many aircraft.

The Republic Airlines DC-9 Flight Simulator Used by Midwest Express.--The Republic Airlines DC-9-10 visual flight simulator was initially FAA-qualified for flight training in 1966. The simulator was manufactured by Singer-Link and is equipped with a Vital IV, two-window visual system. The simulator resembles the cockpit configuration of the Midwest Express DC-9-14 airplanes with minor differences which are addressed during training sessions. The simulator has 3 dof motion cues. It contains a control panel which allows the instructor to

insert indications of abnormal and emergency situations into the simulated flight regime for training purposes. Emergency procedures that have been approved for the simulator include engine-out climb performance and abnormal and emergency procedures associated with takeoff and climb. In the simulator, engine failures are reproduced as if by shutting off fuel abruptly.

A review of maintenance records and a discussion with Republic Airlines and FAA personnel revealed that the DC-9-10 visual simulator, used by the Midwest Express crew in training, was modified after the accident, in February 1986, to improve its lateral handling engine-out characteristics to more closely approximate the performance of the airplane. The most significant changes involved adjusting the engine offsets from 14.2 to 6.8 feet. The yawing moment, due to rudder deflection, was reduced by 36 percent. The yaw damper travel was reduced from 5° to 1.5°. Republic personnel stated that the simulator performance now matches the airplane. This view also was expressed by DC-9 test pilots who flew the simulator and then were involved in the Safety Board's flight demonstration in June 1986.

The Midwest Express flight 105 pilots and all other pilots who flew the simulator before these adjustments were made would have experienced more initial rolling movement (simulating lateral acceleration) following a simulated engine failure than they would with the simulator in its present condition. The rudder pedal feel would have remained similar.

1.17.5 FAA Repair Station Surveillance and A.C.E.S. Inspection Procedures.

A.C.E.S. has specialized in JT8D engine repair and overhaul since 1977. The company was moved to its current Miami, Florida, location in April 1982 to allow expansion of the business. About the same time, the company's name was changed to AeroThrust Corporation, but its ownership, management, and employees remained the same and the company continued to specialize in JT8D engine repair. The company was inspected at its new facility, found to meet all applicable requirements, and recertified by the FAA on May 12, 1982.

Surveillance of AeroThrust is performed by the FAA FSDO in Miami. The Principal Maintenance Inspector (PMI) assigned to monitor AeroThrust at the time of the accident reported that his other responsibilities included four air carriers and six repair stations. He said that he had similar responsibilities in 1981-82 when he had been responsible for surveilling A.C.E.S. He reported that the Miami FSDO had about 28 maintenance inspectors in 1981. He said that FAA surveillance of repair stations was a relatively low priority, unless a problem became known. In that event, he said the priority would be elevated and he would deal with the problem. The PMI said that he had not encountered any serious problems at AeroThrust. His visits to AeroThrust were admittedly infrequent, but he said there were no problems to warrant more frequent visits. He also said that, although there had been an FAA requirement to document all such visits, the AeroThrust file did not contain records of all visits. Safety Board investigators reviewed the Miami FSDO file on AeroThrust and found that there were infrequent visits to AeroThrust (typically not more than three per year before the Midwest Express accident), and that there were no documented visits from November 2, 1979, to November 5, 1981.

FAA PMI responsibilities regarding repair stations are contained in FAA Order 8300.9. Inspectors are responsible for determining the qualifications of applicants for Air Agency (Repair Station) Certificates by examining the facilities and evaluating company personnel. Also, inspectors are required to inspect periodically the facilities to determine continuing compliance with FAR 145 requirements on an "as needed basis" at the discretion of the local district office. The order does not establish a frequency of visit standard.

The PMI said that he had never seen any customer complaints about AeroThrust work; none were found in the FAA file. He was not aware of any history of spacer failures in engines overhauled by AeroThrust, and there were no

records of any in the FAA file.

The only documents in the FAA AeroThrust file addressing the removable sleeve type high pressure compressor spacer were correspondence between AeroThrust and Air Florida in late 1982 and early 1983, and between the FAA and Air Florida, dated May 3, 1983. Those letters were not critical of AeroThrust. The FAA letter advised Air Florida to take action, "as deemed necessary" with regard to continued use of removable sleeve spacers.

The FAA Miami FSDO performed a General Aviation Safety Audit (GASA) of AeroThrust on November 16, 1984. All noted discrepancies were administrative in nature and did not involve defective rework, inspection, or assembly of parts. However, the report did not contain a response to the questions:

1. Are supervisors and inspectors properly trained and qualified?
2. Is the required training verifiable through company records?

The FAA inspectors who performed the inspection did not recall the 1984 status of AeroThrust training records. They thought they had examined those records, but could not explain why the GASA form was not completed to reflect the results of their inspection. The followup to the GASA inspection (reinspection of the noted discrepancies) was not performed by the PMI until June 5, 1985. At that time, all formerly deficient areas had been corrected, although there was no record of followup with regard to the aforementioned questions that were not answered previously.

The A.C.E.S. Inspection Procedures Manual, dated January 11, 1979, which was in effect at the time of the 1981 spacer refurbishment, established the following inspection standards:

- a. All inspection personnel must be thoroughly familiar with all inspection methods, techniques and equipment used in their speciality;
- b. They must maintain proficiency in the use of various inspection aids;
- c. They must be familiar with current inspection limits and tolerances.
- d. Where magnetic particle inspection is used, the inspector must be competent to properly interpret defects.
- e. Inspectors performing crack detection must have their vision checked once a year.

FAA Miami FSDO personnel report that although the 1979 Inspection Procedures Manual did not specifically state that AeroThrust must maintain training files on all of its inspection personnel, the FAA has required that such records be maintained in the past so that repair stations may demonstrate with those records their compliance with the provisions of 14 CFR 145.43. That regulation requires repair stations to provide a summary of the employment experience in the type of work being performed by its inspection personnel. Another applicable regulation, 14 CFR 145.45, requires repair stations to be thoroughly familiar with all inspection methods, techniques, and equipment used in their speciality and to maintain proficiency in the use of that inspection equipment. The 1979 Manual was subsequently revised in May 1985 and approved by the FAA PMI. The manual now requires that AeroThrust maintain records of the training of each employee. AeroThrust personnel and the PMI reported that most training at AeroThrust is conducted on-the-job, as was the practice in the past.

The employee who performed the FMPI on the right engine 9-10 spacer during its overhaul in October 1981 had been an inspector with the company since 1966. A company spokesman testified that the inspector was trained on-the-job by a Magnaflux Corporation service representative in 1966. The Magnaflux service representative visited the inspector weekly in 1966, but the visits became less frequent as the inspector became more proficient.

Magnaflux service representatives still inspect annually the Magnaflux H720 FMPI equipment for normal operation. The inspector's training record did not reflect how he was qualified on the H720 equipment used by A.C.E.S. and AeroThrust. Also, AeroThrust records did not show whether the inspector's vision was checked on an annual basis before 1981, consistent with the requirement specified in the Inspection Procedures Manual.

The AeroThrust H720 inspection equipment is inspected yearly; however, fluids and blacklight used with the equipment are inspected monthly. The ammeter is checked every 6 months. AeroThrust requires inspectors using the H720 equipment to check daily that the equipment is operating properly, using test pieces. Complete H720 inspection equipment records for 1981 were not available, although records indicated that the blacklight was checked monthly and that the ammeter was checked once each 6 months in 1981.

There was no formal training program for FMPI (Magnaflux) inspectors at A.C.E.S. in 1981. Also there was a general lack of written procedures in the shop in 1981 and as late as 1984. Company management said that detailed procedures in the shop had not been necessary in the past because the workers had specialized duties and knew the necessary details of their jobs.

AeroThrust and A.C.E.S. have twice requested shop reviews²⁷ by Pratt & Whitney (1980 and 1984). The shop reviews were reportedly not brought on by shop deficiencies. The FAA was not invited to participate in these shop reviews nor was there any requirement for FAA participation. Neither was the current PMI aware of the shop reviews until they were brought to his attention during the accident investigation. He testified that had he known of the findings of those inspections, he would have been obligated to investigate the matters further and to possibly take enforcement action against AeroThrust to assure corrective action on some of the cited deficiencies. A Pratt & Whitney engineer who participated in the 1984 shop review testified that AeroThrust was an average or above average JT8D repair station, by comparison to other similar facilities which he had inspected; he did not consider the AeroThrust discrepancies noted by Pratt & Whitney to be safety deficiencies. He said most of the items were noted to improve AeroThrust efficiency. He said that AeroThrust was more responsive to the Pratt & Whitney recommendations than any of the other facilities where he had performed such inspections.

1.17.6 Actions to Prevent Spacer Fractures

Following 11 fractures of removable sleeve spacers in 1979 and 6 fractures which occurred in 1980, Pratt & Whitney, in cooperation with the FAA, distributed a series of "All Operator Wires" and "All Operator Letters." The letters described the fractures, identified typical crack initiation sites, and provided maintenance recommendations which were intended to prevent fractures. Pratt & Whitney also conducted manufacturer/operator conferences for the purposes of increasing operator awareness of the spacer failure problem and for disseminating new, more stringent inspection and repair techniques for the spacer assemblies. During the same period, integral sleeve spacers (which did not require the press-fit tubes for alignment with tierods) were developed for the 7-8 and 8-9 stages. The 9-10 stage integral sleeve spacer had been introduced as a product improvement in 1972. Pratt & Whitney recommended the use of the integral sleeve spacer, which had a better durability and reliability record, in an All Operators Letter dated June 30, 1980. The letter stated, in part:

The excellent reliability record of integral spacers leaves no doubt that fleetwide retrofit of the removable sleeve type spacer with integral spacers is the ultimate solution to the problem of spacer barrel fracture.

Pratt & Whitney revised the JT8D maintenance manual in 1981 to accomplish the following regarding removable sleeve spacers:

1. Provide for uniform cutback of knife edges to remove small, hard-to-detect cracks.
2. Emphasize the need for removing sleeves from spacers when fluorescent, magnetic particle

inspection was accomplished.

3. Provide for ultrasonic inspection.
4. Recommend CERMETEL coating to reduce the potential for cadmium embrittlement caused by inadequate nickel cadmium plating.

A Pratt & Whitney Product Support Engineer testified that mandatory replacement of removable sleeve spacers was not recommended in 1980-81 because the manufacturer believed that the maintenance manual revisions would adequately address the problem. Service failures continued; however, the fracture rate dropped substantially after 1980 (one failure each in 1981, 1982, and 1983; three failures in 1984; and two failures in 1985).

Following an uncontained spacer disintegration in 1982, an All Operators Letter was issued on December 23, 1982. The letter reemphasized the importance of careful spacer inspection during periodic engine teardown and again recommended replacing the removable sleeve spacers with integral spacers if economically feasible. The letter stated, in part:

During a recent operator survey to determine the extent of compliance with our inspection and repair recommendations for removable sleeve spacers we also included an inquiry relative to positive operator programs to retire these spacers and replace them with integral spacers. The response was disappointing. In spite of our recommendations, very few operators have positive programs for the timely incorporation of integral spacers. In order to stimulate airline interest in replacing the removable sleeve spacers with the integral design for the 7-8 and 8-9 stages we have recently included these parts in the Order Performance Incentive Plan Catalog.

According to the manufacturer's estimates, more than 7,000 spacers of the removable sleeve design were still in service on JT8D engines in November 1985, despite the fact that the newer, more reliable integral spacer was available for retrofit. At the time of the Midwest Express accident, the FAA had not issued any regulatory requirement to install the improved integral sleeve spacer in the JT8D engine and neither the FAA nor Pratt & Whitney had modified the JT8D engines of their own airplanes with integral sleeve compressor spacers although there had been 45 previous failures of removable sleeve spacers in JT8D engines. Airworthiness Directive 86-08-04, discussed in Section 2.7 of this report, was issued by the FAA on May 13, 1986.

2. Analysis

2.1 General

The examination of the events that led to the accident began with a review of witness observations in conjunction with the ATC radar and CVR and FDR data. Witnesses were consistent in their descriptions of the performance of the aircraft during the takeoff roll, rotation, liftoff, and initial climb. The observation by one DC-9 qualified pilot that the rotation to a takeoff attitude seemed abnormally abrupt was inconsistent with all other witness observations and was not corroborated by the FDR data. The aircraft performance data, subsequent to the liftoff, was consistent with normal two-engine operation and disclosed evidence that all flight controls were functioning through the period of takeoff roll, rotation, and initial climb before the right engine failure. Thus, the Safety Board concludes that there were no operational irregularities of any consequence in those phases of the flight.

Witnesses were consistent in reporting that their attention was attracted to the airplane because of one or more loud noises, described as "bangs," and similar to "shotgun reports," which occurred about the same time they saw flames and/or smoke from the right engine. The audible "bang," associated with an engine failure was confirmed by the

CVR. Witnesses did not describe flame emitting from any part of the aircraft other than the right engine. Examination of the airplane confirmed that there was no in-flight fire other than that contained within the right engine. The witnesses estimated that these events occurred about 300 feet a.g.l. It was determined that the right engine actually failed about 450 feet a.g.l.

Sixteen witnesses reported that the aircraft seemed to decelerate following the right engine failure, consistent with FDR data. The deceleration of the airplane was caused primarily by the loss of thrust from the right engine. The deceleration also was influenced by sideslip-induced drag and a reduction of left engine thrust. Reduced airspeed and increased G load made the airplane susceptible to accelerated stall. The presence of sideslip made the airplane susceptible to rolling motions.

Correlation of the FDR, CVR, and air traffic control data allowed the Safety Board to make several determinations regarding the flight. The airplane was climbing about 168 knots with a 50-foot per second rate of climb when the right engine suddenly failed. For 3 to 4 seconds, control was maintained with little change in heading, indicating that there was an initial correct (left) rudder pedal application. Accelerometer data showed a reduction of normal G loads, indicating that the airplane's pitch attitude was lowered, apparently to reduce the rate of climb and to prevent a deterioration in speed. The left rudder pedal application and reduction of the airplane's pitch attitude were consistent with the normal flight control responses following loss of thrust from the right engine of a DC-9 airplane. About 4 seconds after the right engine failed, the airplane began to yaw rapidly to the right, as indicated on the FDR data by the 20° heading change from the third to the seventh second (after the right engine failure), while the radar data indicated that the airplane was continuing in a relatively straight track. The yaw rate was greater than that which would have occurred due to a sudden loss of right engine thrust, or a sudden release of the rudder pedal force used to compensate for the asymmetrical thrust.

The Safety Board determined that the sideslip angle reached about 15° and that the total yaw reached 20° during this interval. The airplane heading deviated even farther to the right and at a more rapid rate from the eighth to the ninth second, indicating that a large roll angle was developing. As the airplane started to descend, the normal acceleration forces increased rapidly. About 1 second later, 9.6 seconds after the right engine failure, the stall warning stickshaker activated when the normal acceleration indication was 1.5 G. Normal acceleration increased to about 1.8 G while the descending right turn continued, indicating that the airplane entered an accelerated stall at about 148 knots. The airplane crashed about 5 seconds later. **(See figure 5.)**

The large heading changes which occurred later than the ninth second after the engine failed could not have occurred without the development of a large roll angle, in addition to right rudder deflection. Also, the ground track was not consistent with heading change due to roll angles, and the low normal accelerations (less than 1 G), which were recorded in this interval, would diminish the effects of roll angle on the heading change rate. Therefore, the Safety Board concluded that the sudden heading change which occurred before the eighth second after the right engine failure was caused by a yawing moment, rather than a rolling moment.

The Safety Board believes that the configuration of flight 105 did not change after gear retraction. The flaps probably remained at 20° deployment until impact when they were driven farther downward to about 28°. In other DC-9 accidents, the Safety Board has found similar flap movement during the impact sequence. There was no evidence that the flightcrew initiated efforts to land the airplane.

The investigation revealed that the flightcrew was medically and operationally qualified for the flight. They had received sufficient rest, and no evidence of adverse stress-related factors was found. Weather and air traffic control were not considered to be factors in the accident.

N100ME was certified, maintained, and equipped in accordance with applicable FAA regulations and approved procedures. The original airplane certification process had required demonstration of relevant handling qualities of the airplane, including conditions normally encountered in the event of sudden loss of thrust of either engine. The

results of this investigation did not reveal any handling characteristics of the DC-9-14 which were inconsistent with the original standards for certification of the airplane. For example, the pilots who participated in the Safety Board's DC-9-14 flight demonstration described the airplane's handling characteristics as docile, even after the sudden and complete loss of thrust from the right engine in a simulated takeoff/climb phase of flight. Consequently, the Safety Board concludes that the loss of control of the airplane was not directly attributable to the loss of thrust from the right engine.

The analysis of this accident thus examined those factors which, in conjunction with the failure of the airplane's right engine, might have caused the pilots to lose control. Those factors included:

- The possibility that fragments of the right engine separated with sufficient energy and trajectory to cause critical damage to the airplane's flight control system;
- The possibility of control system malfunction(s) which, in combination with a single or dual power loss, could have rendered the airplane uncontrollable;
- The possibility of a mechanical failure of the left engine, either related or unrelated to the failure of the right engine, which left the airplane with insufficient thrust to maintain flight; and
- The possibility of inappropriate flightcrew response to the emergency presented by the failure of the right engine.

To resolve the factors which precipitated the loss of control, it was first necessary to examine the circumstances of the failure of the right engine.

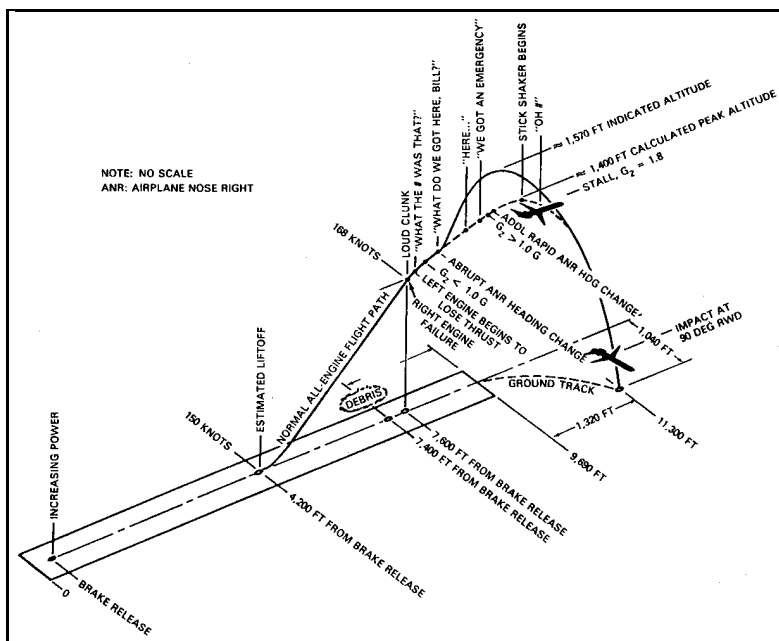

Figure 5.—Representation of the estimated flightpath and sequence of events.

2.2 Right Engine Failure and Secondary Damage from Uncontained Engine Parts

The physical damage to the engine and the condition of the inlet fan blades and low pressure compressor blades indicated that the right engine had little or no rotation at impact with the ground. The sound spectrum examination of the CVR-recorded engine sounds also indicated that this engine lost rpm very rapidly after the engine failure.

The hole in the high pressure compressor in the plane of rotation of the 9-10 stage removable sleeve spacer and the damage to the compressor and spacer revealed conclusively that the spacer had ruptured in flight and that the spacer parts were not contained by the engine casing. The ejected spacer parts had ruptured the rear skirt intermediate case at the 11 to 1 o'clock position, leaving a 4-by 7-inch opening in the top of the case. The loss of the spacer and consequential damage within the right engine caused a rapid deceleration and a complete loss of thrust from that engine.

The Safety Board based its analysis of the trajectory of ejected engine parts from the right engine on the following: (1) Pratt & Whitney's experience in other incidents which involved rotor and spacer uncontained failures, (2) the research described in the D.McCarthy report, (3) the physical evidence obtained in examination of the right engine and locations of debris at the accident site, (4) the analysis and data contained within the submissions of the parties to the Safety Board's investigation of this accident, and (5) the Safety Board's engineering analysis of the trajectory of engine parts.

Calculations showed that, from the point at which spacer parts were actually ejected from the right engine, the distribution of the parts found near runway 19R was as predicted for undeflected parts existing the right engine. **(See figure 6.)** The ejection paths of a few spacer pieces and compressor blades pieces could not be resolved because those parts were not found. However, based on the paths of the recovered debris, the Safety Board concludes that part of the spacer was probably ground into tiny, harmless pieces during the rupture and that part of the unaccounted for spacer pieces and blades might have been missed, despite a thorough search for engine debris in the grass adjacent to the runway.

Calculations showed that the deflection of engine parts by the engine casing or cowling would have resulted in the absorption of energy of the deflected parts, thereby reducing the velocity substantially and limiting the potential to produce any damage of consequence to the fuselage or to the control systems. For example, engine containment tests have shown that ejected engine debris which is deflected more than 33° loses virtually all of its energy.

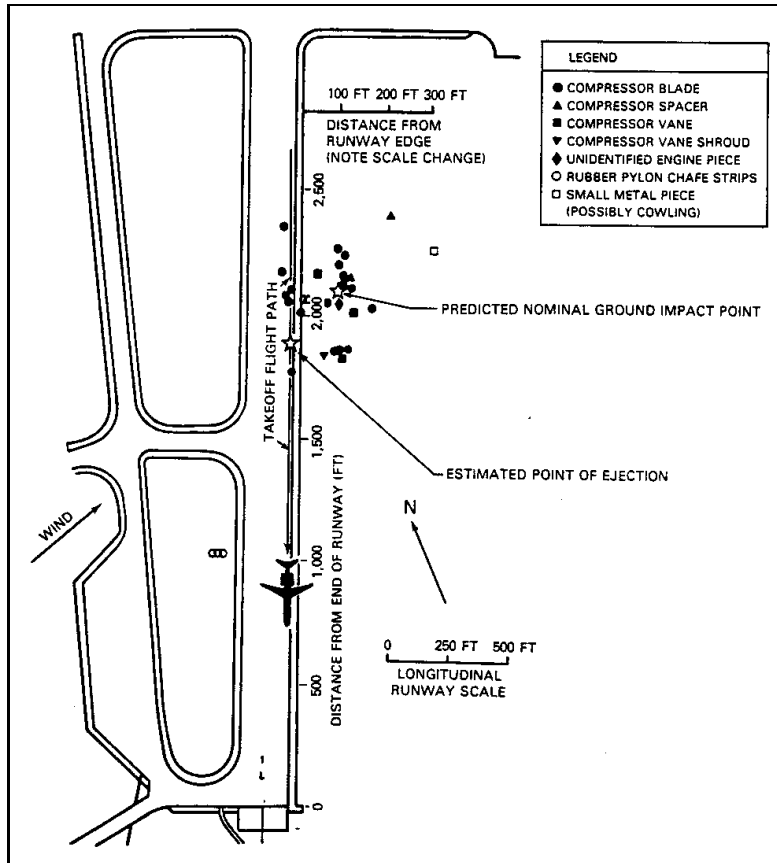

Figure 6. --Calculated nominal ground impact point and actual locations of engine debris adjacent to runway 19R.

Figure 7 shows that undeflected parts are initially ejected in a direction approximated by the broomstick method; in this case, 20° outboard of vertical (away from the airplane fuselage) with high energy and speed. To have struck the Midwest Express fuselage, the parts would have had to have been deflected in excess of 65° and thus virtually all energy would have been lost.

Study of the DC-9-14 control system revealed that all of its components which pass through the aft fuselage pass the engines below the cabin floor level. All were protected by multiple layers of aircraft structure. Therefore, for ejected engine parts to have struck and damaged any of these control system components, the ejected parts first would have to have been deflected more than 120° from their initial tangential ejection path and then would have to have penetrated and continued through engine cowling, engine pylon, fuselage, possibly fuselage supporting structure, the cabin floor, and possibly several intercostal floor beams. Having reached the control system component(s), sufficient energy would have to have remained to disable the system components. The Safety Board believes that the possibility of ejected engine parts reaching internal control system components was extremely remote, if not impossible.

The possibility of parts penetrating the fuselage at a point farther aft and damaging control components in the vertical fin would have been even more remote. Relatively low velocities would have been required for parts to have progressed in that direction and to have struck the airplane, while high energy would have been required to penetrate the fuselage structure. Moreover, examination of the control system revealed redundancies which would

have allowed the flightcrew to maintain full control of the airplane even if some control systems had been disabled. Also, it was found that the rudder hydraulic actuator, which controls rudder movement by hydraulic pressure or by transferring control input to the aerodynamic tab, showed no evidence of preimpact damage. Additionally, the rudder power shutoff valve was found with a bent control rod and discoloration, consistent with rudder hydraulic power on at ground impact.

The Safety Board also examined the possibility that the right engine cowl was blown open in flight or became distorted to such an extent that excessive drag was produced, affecting controllability of the aircraft. Although the right engine upper cowling was extensively damaged by impact forces, all four outboard latches remained latched. There was no evidence to indicate that the right cowl had opened in flight. All recovered right cowl pieces which could be positively identified were found within the impact area. Although a small (2- by 2-inch) piece of metal which resembled cowl material was found near runway 19R, it was determined that each square foot of deformed cowling would produce drag equivalent to a reduction of engine thrust by 100 pounds—a minor factor. Based upon the small hole (4- by 7-inch) found in the right engine case, the absence of other case deformation (other than impact damages), and the characteristics of typical uncontained engine pieces ejected at high velocity, the Safety Board concludes that the cowling deformation probably was small and therefore caused very little additional drag following the right engine failure.

2.3 Flight Control System Failure or Malfunction

The Safety Board considered the possibility of a flight control system failure or malfunction, unrelated to the right engine failure, that might have occurred simultaneously or nearly simultaneously with the right engine failure, and that subsequently led to the loss of control. The Safety Board does not believe that such a failure or malfunction occurred for several reasons, including those reasons cited previously regarding possible damage caused by the right engine failure. In addition, an analysis of the control movements, which would have been required (commanded or otherwise) for the airplane to have maneuvered as indicated by the FDR, revealed that:

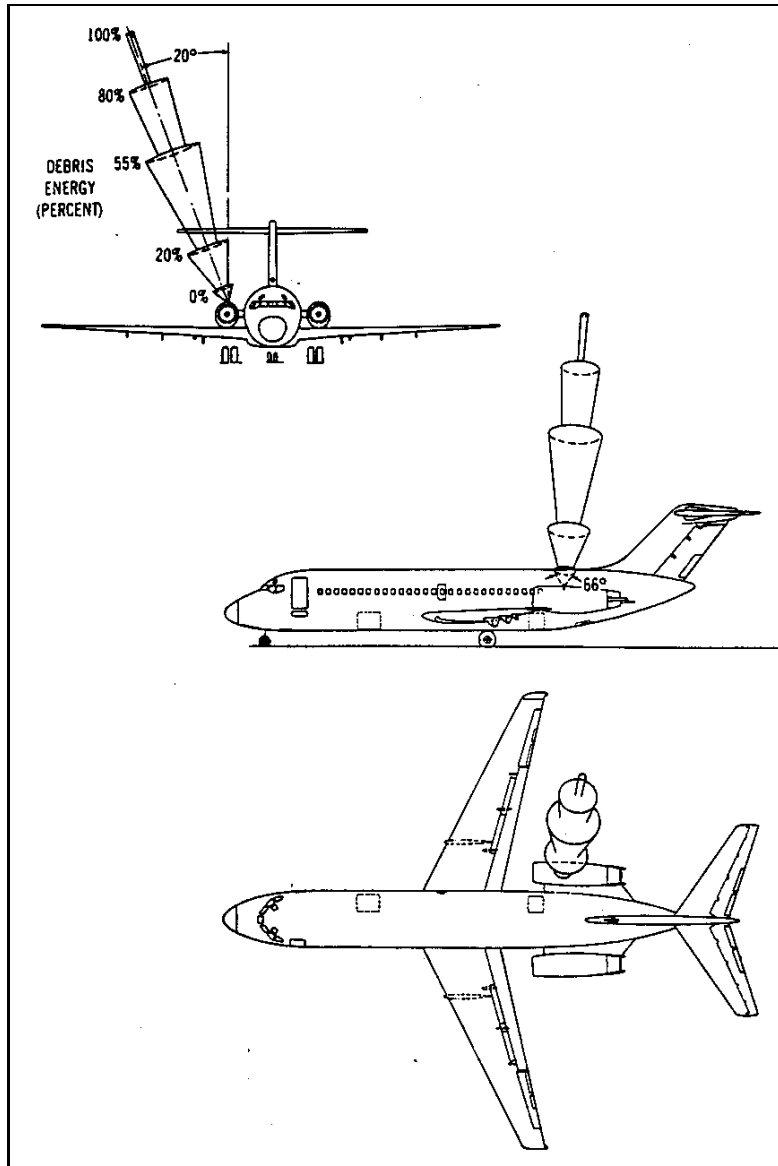

Figure 7.--Three-view drawing of a DC-9 series 10 airplane with various debris patterns and corresponding percentage of energy loss.

1. Rudder deflection to the left was required for the airplane to maintain heading for 4 seconds immediately after the right engine failure;
2. Rudder deflection to the right was required to cause the heading change which occurred from the 4th to the 10th second after the right engine failure;
3. Elevator control was required to cause the pitch-over and pull-up maneuvers which were documented by the FDR acceleration traces after the right engine failure; and

4. Aileron/spoiler deflection was required for the airplane to maintain the roll attitude in the presence of large sideslip angles which were documented.

The Safety Board also considered the possibility that the captain's left rudder pedal support arm fractured after he deflected the left rudder pedal. Even though the fracture mode of the pilot's pedals could not be determined conclusively from metallurgical examination, there was no evidence that a pedal failed during a critical phase of flight. Review of CVR sounds revealed no noise or flightcrew response that could be associated with such an event. The similarity of the fractures on both the captain's and copilot's pedals suggests that they were subjected to similar forces at failure, most probably overstress at impact. Furthermore, failures of rudder pedals in past incidents occurred during braking actions while on the ground, rather than during in-flight operation because rudder control forces applied in flight produce less stress on the pedals. Finally, failure of the left rudder pedal would result in return of the rudder to a near-neutral position, and would not account for the deflection of the rudder to the right. Therefore, the Safety Board concludes that the rudder pedal support arm fractures were caused by overstress forces at impact and were not related to the cause of the accident.

In conclusion, the Safety Board determined, after examination of the wreckage, trajectory study calculations, and research into the DC-9-14 control system, that engine parts probably did not strike the aircraft after being ejected from the right engine. The Board believes that if any of the small engine parts actually struck the aircraft, no damage of any consequence would have occurred as a result of that contact. The Board found that there was no basis upon which to conclude that flight control systems malfunctioned or were damaged in flight, secondary to the right engine failure, and that all of the onboard flight control systems on N100ME were available to the flightcrew following the abrupt loss of right engine power.

Further, electrical power was available to the crew of flight 105 until impact based upon the continuous operation of the FDR and the CVR and the elongation of the right wingtip navigation light bulb filament, which indicated that the filament was hot and, therefore, on when subjected to impact forces.

2.4 Left Engine Power Loss

The Safety Board does not believe that the left engine power loss was significant with respect to the eventual loss of control of the airplane. Any reduction in left engine thrust that occurred before stickshaker would have reduced the yawing of the airplane which occurred after the right engine failure. While possibly necessitating a forced landing, a left engine power loss should not have precipitated, or even contributed to, a loss of control of the airplane. However, the reduction in left engine power could have confused the crew. A detailed discussion of the Safety Board's analysis of the left engine mechanical condition and operation is contained in appendix I.

2.5 Evaluation of Flightcrew Response

The flight demonstration of a DC-9-14 airplane showed that with a sudden loss of right engine thrust at 170 knots, lateral and directional control could be maintained even if the pilot took no immediate action to deflect the rudder. Under these conditions, the airplane experienced about an 8° heading change and developed about 5° of sideslip within 4 seconds. About 30° of control wheel deflection, or 8° left deflection of the rudder, was required to maintain a wings-level attitude of the airplane. The flight demonstration was conducted with about 9,500 pounds of continuous thrust on the left engine (in-flight takeoff power).

The sound spectrum examination disclosed that, on the accident airplane, the left engine thrust dropped from 10,750 pound (initially) to about 9,500 pounds after 2 to 3 seconds and to 5,500 pounds at the time of the loss of control.

Because of the reduced asymmetric thrust, the yawing moment would have been reduced considerably on the accident airplane, similar to the demonstration airplane. Since there was no difficulty in compensating for the thrust asymmetry on the demonstration flight, the Safety Board concludes that the yawing moment should have been controllable in the accident airplane.

Since the airplane maintained its heading for the first 3 to 4 seconds after the right engine failed, it was concluded that the rudder was deflected properly to the left during that interval. However, based upon calculations of the airplane's yawing response and resultant ground track for various rudder deflections and roll angles, the Safety Board determined that the large heading change and sideslip angle that developed after the first 4 seconds could not have been accomplished without a deflection of the rudder to the right, followed by a roll to the right 4 to 5 seconds later.

Based upon the known performance of a DC-9-14, the closest duplication of the heading change which occurred on the accident flight (indicated by the FDR) would require the rudder to be deflected 6° to the left for about 3 seconds, followed by a rapid return of the rudder to neutral, then deflection of the rudder 12° to the right about 5 seconds after the right engine failure. Returning the rudder to neutral and holding neutral rudder, after initially applying rudder to correct for differential engine thrust, would not have created the heading change rates which were indicated by the FDR data. Likewise, a system malfunction which would cause the rudder to trail in a near-neutral position would be inconsistent with the FDR-indicated heading change data.

The demonstration flight in a DC-9-14 airplane showed that the airplane had no control characteristics which were inconsistent with the applicable certification standards; the airplane was found to be fully controllable in an engine-out flight environment, even without using rudder (the primary control for correcting yaw and maintaining heading) to correct for yaw. Having found no evidence or airplane performance basis for concluding that there was a control system failure or malfunction, the Safety Board concludes that the rudder deflection, which occurred beginning 4 to 5 seconds after the right engine failure, was the result of the flightcrew's improper response. Based on the analysis of the airplane performance, the yaw generated by the incorrect rudder deflection, combined with G loading, caused the airplane to enter an accelerated stall at an altitude too low for recovery.

In the seconds which preceded the accelerated stall and loss of control, the airplane was in a very dynamic situation. The increasing rate of roll, the sideslip, and the increase in acceleration load all affected adversely the stall speed. Because of the rapidly changing attitude of the airplane, the pilots would not have been expected to know the speed at which the airplane would stall in accelerated flight. Compared to the increase in stall speed, the 8-knot error in indicated airspeed (due to static source error in a sideslip) would not have been significant. Further, the stickshaker stall warning system would not and did not provide the customary 4 to 5 seconds warning which is typical of that system because of the rapid entry into the stall. The Safety Board concludes that the stall occurred because the flightcrew did not diagnose the nature of the emergency correctly, applied incorrect rudder control about 4 to 5 seconds after the right engine failure, and applied nose-up elevator control which increased the G loads. The nose-up elevator control input would have been a normal response to correct for the pitch-over maneuver and the reduction in pitch attitude which was precipitated by the rudder pedal induced roll and was consistent with the rapid deceleration of the airplane. The rapid deceleration would have resulted in a vestibular perception of downward pitching of the nose of the airplane.

The Safety Board believes that more effective scanning of the flight and engine instruments by the pilots of flight 105 would have enabled them to maintain control of the airplane and to properly evaluate the powerplant anomalies. The failure of the first officer to respond to the captain's questions and the failure of the captain to maintain control of the airplane suggests that there was a breakdown in instrument scan by both pilots in the critical seconds which followed the right engine failure.

In view of the finding that the loss of control of the airplane probably was caused by the flightcrew's improper

response to the engine out emergency, the Safety Board examined several factors which could have contributed to the flightcrew's improper actions.

2.5.1 Flightcrew Training and DC-9 Qualification

Airlines larger than Midwest Express, with many more years of operating experience and larger pilot populations, upgrade pilots to captain based on demonstrated ability to accept the responsibilities of the position, sufficient seniority to successfully bid on the position, and completion of the required training. Midwest Express uses the same criteria; however, with a smaller pilot population, advancement to captain can occur much sooner, as indicated by the advancement of the flight 105 pilots. Pilots at the more established airlines must have a great deal more seniority and thus have more pilot experience in turbojet airplanes before captain upgrade because of the relatively slow growth of those airlines. Because of the DC-9s relatively small size in their fleets, it is typically the first turbojet airplane in which many airline pilots upgrade to captain. Based on a sampling of recent upgrades to captain at two airlines, which the Safety Board believes are representative of carriers providing most of the scheduled passenger service in the United States, the Board determined that, by comparison, both pilots of flight 105 were relatively inexperienced in turbojet operations. For example, the experience level of recent DC-9 captain upgrades at the two airlines was: in excess of 10 years' seniority with the company, in excess of 10,000 hours total pilot experience including more than 7,500 turbojet hours as first officer, and generally served as a flight engineer for more than 3 years before upgrading to first officer. The Safety Board does not believe that much experience is essential for initial upgrade to captain of a DC-9; however, extra experience does provide a greater margin of safety to the traveling public.

By contrast, the captain of flight 105 had been employed by Midwest Express for 12 months and had 600 hours of turbojet experience as a DC-9 first officer (no flight engineer experience) at the time of his captain upgrade. He had no turbojet or sweptwing airplane experience before being hired by Midwest Express. The first officer of flight 105 had previous turbojet experience in the U.S. Air Force before his Midwest Express employment. He was upgraded to DC-9 captain with only 500 hours experience in the airplane.

Both flightcrew members received training that was in accordance with FAA regulations. The first officer, who had received DC-9 instruction from USAir as well as Republic Airlines, was described by instructors of both carriers, independently of each other, as an excellent pilot. Republic Airlines' officials were pleased with the attitude of Midwest Express in that it willingly encouraged Republic to provide all the training Republic believed necessary, within reason, to train its pilots to proficiency.

The Safety Board concludes that the training that the crew received met all applicable standards. Training to proficiency, a practice used by Midwest Express, is a sound educational practice used in many professions. However, the Board is concerned about Midwest Express utilizing a "silent cockpit" philosophy which was not outlined in its approved training and operations manuals and which is contrary to other procedures which are published in approved manuals. The Safety Board believes this conflict may have resulted in less crew communication and coordination than otherwise might have been demonstrated.

The Safety Board is aware that pilots with substantial experience in multiengine airplanes usually have received considerable training in engine-out emergencies and have had opportunities to practice appropriate emergency responses during initial and recurrent training. Several pilots confirmed these facts in their testimony at the public hearing on this accident and stated that a pilot's reaction, in applying proper rudder pedal forces in response to an engine-out emergency, can become reflexive because of that training and previous pilot experience.

Also, the Safety Board is aware that pilots have occasionally misidentified a failed engine in previous accidents and incidents and have erroneously shut down still operative engines. In the course of this investigation, the Safety

Board learned of several simulated engine failure incidents in which pilots responded initially with deflection of the incorrect rudder pedal in the DC-9 airplane. A Douglas test pilot, who had flight instructor experience in the DC-9, testified to a personal experience where a pilot who was receiving DC-9 instruction commanded rudder deflection in the wrong direction in response to a simulated engine failure. An FAA DC-9 instructor, with extensive training experience, testified that about 1 of every 50 of his students, each of whom held an airline transport pilot certificate, had attempted to deflect the wrong rudder pedal during simulated engine failures on takeoff. The Safety Board attempted to identify other DC-9 engine failure incidents which occurred after takeoff, while at low altitude, and found that such incidents have been infrequent in this critical flight regime.

The Safety Board also found that the majority of engine-out training provided to Midwest Express pilots in the takeoff regime occurred near V1 when the simulated airplane's pitch attitude was low, which provided outside visual references, including a runway centerline which were not available to the pilots of flight 105. There was very little exposure in training to the potential errors which might occur in response to an engine failure after gear retraction in the climb phase when the airplane's pitch attitude is near 12° nose up. In this accident, with only a clear blue sky visible through the windshield, the flightcrew would not have had the outside visual references that were available during most of their emergency training. Consequently, a clear, blue sky would not have provided lateral motion cues related to sudden yaw or the roll reference that were available during V1 engine out training in the simulator.

Recognition and response to engine failures are stressed in pilot training and certification programs. Airline pilots are required to demonstrate their proficiency in these skills during initial and recurrent flight checks. The Safety Board closely examined aspects of the training in recognition and response to engine failure to determine if some aspect of the training could account for the crew's failure to respond appropriately to the emergency.

2.5.2 Engine Failure Recognition and Response

Several facts emerge when considering the influence of pilot training in response to engine failure. First, engine failures have become highly improbable events since the advent of modern, reliable turbojet engines in air transport operations. When reciprocating engines were widely used, it was not unusual for experienced pilots to encounter an engine failure in flight. Today, the opposite is true. Second, the criticality of response to engine failure is directly related to the particular phase of flight in which it occurs. When the airplane is closest to the ground, it is obvious that proper response to the failure must be immediate because time available to make decisions and to execute procedures is limited. At the same time, an airplane's airspeed is low (and closer to stall) when it is close to the ground. Thus, in takeoff or landing phases of flight, response to an engine failure must be immediate and appropriate. In other phases of flight, where delayed recognition or an improper response to an engine failure could result only in the loss of altitude and/or airspeed, a margin for error is available that is not available on takeoff or landing. Third, a failure in a turbojet engine does not always result in an abrupt (occurring in less than 0.5 second) loss of power.

Abrupt failures, such as that experienced by flight 105, are rare occurrences within a category of events that is itself unusual. While pilots are trained to recognize and respond to engine failures, the training is not generally in response to an abrupt loss of power. When pilots practice recognition and response to engine failure in an airplane, particularly at low altitude, to do other than retard the throttle to flight idle to simulate an engine failure (where residual thrust is still generated) can seriously compromise flight safety. Thus, it is necessary to conduct such training in flight simulators which do not respond exactly as the airplane, following an abrupt loss of power. However, pilot response to the engine failure should be the same regardless of the cause of the failure even though the cues which the pilot perceives may vary depending on the characteristics of the failure.

Consequently, although a pilot's response to engine failure in a twin engine airplane should be invariant, that is, the

pilot must fly the airplane safely maintaining directional control through the use of rudder primarily and aileron to a lesser extent, the recognition and resultant speed of the response may be affected by the interaction of the type of failure experienced and the phase of flight in which it is encountered.

The Midwest Express chief pilot testified that the philosophy of engine failure procedures and crew response to those procedures is based upon the criticality of the situation. He stated that Midwest Express pilots are allowed more latitude, in terms of their reaction, in responding to engine failures that occur in less critical phases of flight. He categorized an engine failure on takeoff before gear retraction, for example, as being more critical than an engine failure later in the takeoff climb. This viewpoint is consistent with the pilot certification requirements stated in the Federal Aviation Regulations, and it is consistent with the general practice of the airline industry. However, underlying this approach may be an implication that failures that occur beyond V₁, where immediacy of response may not be as critical, might actually encourage a delayed crew response to the failure. Thus, the Board studied the possibility that a perceived lack of criticality in the speed of the response to an engine failure after gear retraction may have led the crew to delay coordination of corrective action in response to the engine failure.

Human factors research involving operators of automobile simulators ²⁸ has shown that reaction time was related to the nature of the stimulus: the more simple and intense the stimulus, the faster the reaction time. Regardless of the factors involved, reaction time was generally measured in fractions of a second. Reaction time to apply stimuli generally required less than 1 second.

The captain's initial reaction to the right engine failure sound was about 1 second, as indicated by his first question to the first officer. The response time to apply correct rudder was about 1 to 2 seconds, based upon the FDR data.

The Safety Board believes that the captain's prompt rudder application was a spontaneous reaction to his kinesthetic cues and was merely an attempt to restore a balanced flight condition. As such, it probably was initiated before he had time to analyze the nature of the emergency. However, following this initial compensatory reaction, the captain, possibly as a result of other kinesthetic and/or visual cues, initiated actions that subsequently resulted in loss of control of the airplane. Because of these improper actions following an in-flight engine failure, and the apparent incorrect interpretation of available cues that prompted them, the Safety Board examined the flight simulator which was used to train the flightcrew of flight 105 to evaluate what effect, if any, that it may have had on pilot ability to recognize the engine failure.

2.5.3 Flight Simulator Training Effectiveness

Much of the Midwest Express required flight training was performed in an approved, 3 dof visual flight simulator. The differences between the simulator and the airplane cockpit layout were minor and were addressed in training. The Safety Board found that visual flight simulators have limitations in reproducing the engine failure emergency as it would be experienced in an airplane since peripheral visual cues, certain onset motion cues, and aural cues were absent in the simulator. This characteristic was not unique to the Republic Airlines simulator but was common to all visual flight simulators.

A human performance expert testified at the Safety Board's public hearing that motion cues were important in training because, without them, the training was not sufficiently realistic and might not prepare the pilot for an actual failure in the airplane. He described the (onset) motion cues which the airplane provided that were unlike those to which the pilots were exposed in simulator training. He said that the absence of those cues in training might cause confusion for a pilot when the cues were experienced in the airplane and that, thus, the pilot(s) might be prompted to make an improper response. However, DC-9 pilots who had experienced dynamic engine thrust reductions in both the simulator and the airplane stated that they did not believe the differences to be significant. Their views were generally supported by the DC-9-14 flight which showed that the lateral accelerations and yawing

motions produced in flight were neither violent nor dramatic.

Because high fidelity flight simulators are a relatively recent development in the training of air transport pilots, applicable behavioral science literature is not consistent on the effects of lower fidelity simulators in pilot recognition of various in-flight phenomena. More important, the large variance in the experience of pilots used as subjects in the research limits the generalizability of the research findings in flight simulator effectiveness in pilot training. For example, the Safety Board cannot conclude that findings based on research involving low time pilots may be generalized to high time pilots. When variables, such as airplane craft complexity and number of engines, are introduced, the generalizability of the research results is reduced still further. Moreover, in air transport pilot training, there is little empirical data that researchers can use to develop conclusions about the importance of specific simulator features on pilot performance. Often, the data that are presented are of limited applicability due to flaws in the experimental design.

Because of the lack of consistency in the behavioral science research on simulator motion, the Safety Board cannot attribute the failures in the performance of the pilots of flight 105 to the lack of high fidelity yaw motion cues in the DC-9-10 visual simulator. While the simulator lacks the immediate kinesthetic yaw motion cues from thrust asymmetry in the airplane, it does replicate the long term lateral acceleration motion cues resulting from an engine failure so that the cues which are presented are similar to the airplane response. Although the pilots of flight 105 may not have experienced the exact kinesthetic and visual cues in their simulator training, the Safety Board believes that they should have been able to recognize and analyze the emergency based on the cues which were present.

However, the Safety Board cannot disregard the possibility that the type of training given in the simulator, rather than the limitations of cues provided in the simulator, could have been a factor in the flightcrew's performance. In particular, the Safety Board is concerned that the takeoff engine failure training involving a loss of thrust as the airplane approaches or passes V1 speed may have been a factor.

In a yawing condition, visual stimuli, which typically produce relatively slower reaction times than aural or kinesthetic stimuli, may enhance the perception of yaw since the pilot normally could see the nose of the aircraft moving sideways relative to objects in his field of view.

In the V1 engine failure, external visual information alone is generally sufficient to inform the pilot of the occurrence, since the airplane is either on, or only slightly above, the runway and the movement of the nose of the airplane, relative to the runway centerline, provides adequate information that an engine has failed. As a result, training in recovery from engine failure at or just after V1 might lead pilots to rely extensively on forward external visual cues, even if peripheral visual cues are present. If the peripheral information is absent, as it is in the simulator, then repeated training in V1 failures in the simulator can result in exclusive use by the pilots of visual information that is presented straight ahead, outside the cockpit.

In this accident, there were no forward external visual references since the sky was clear. At the time the engine failed, the airplane would have been in a nose up attitude of about 12° and the pilots would have been looking at the sky, if they were looking outside the cockpit. In the absence of clouds, there would have been no visual cues straight ahead that could have provided the pilots with the information needed to perceive the airplane's immediate yaw to the right following failure of the right engine. Consequently, the only external visual cues indicating a yaw that would have been available to the pilots would have been ground-based information that was presented peripherally, or the flight instruments. However, peripheral visual cues are of relatively little use for the detection of airplane yaw because the angular rates of stimuli in the periphery are generally too low to be readily apparent.

The Safety Board does not consider the limitations of the visual 3 dof simulator to have been a factor affecting the flightcrew's recognition of the engine failure since pilot training, in general, stresses to pilots the importance of confirming engine and flight control status through the interpretation of cockpit instruments. The simulator is fully adequate in the presentation of these instruments. The training records of the flightcrew of flight 105, as well as the

statements and testimony of their instructor, indicated that they were so instructed. Thus, the engine instruments should have confirmed the engine failure, and the flight instruments should have confirmed the airplane's attitude, airspeed, altitude, and heading.

Nevertheless, the questions asked by the captain and his failure to maintain control of the airplane confirm that he did not correctly interpret the sounds, motion, and other available information. Therefore, the Safety Board believes that the captain reacted primarily to other than visual and flight instrument references, such as kinesthetic cues. He apparently misinterpreted those cues and applied the flight controls incorrectly. This confusion is commonly referred to as "spatial disorientation," and it occurs most frequently at night or in instrument meteorological conditions when few, if any, external visual references exist. Spatial disorientation causes confusion, such as that experienced by the pilots of flight 105, and would account for their incorrect control responses. The only means to prevent such confusion, or to overcome its effects, is for the pilot to rely on the flight instruments.

Therefore, the Safety Board concludes that infrequent training for an engine failure at low altitude in the initial climb phase of flight could have left the flightcrew ill-prepared to cope with the emergency. Although analyzing abnormal or emergency situations and maintaining control of the airplane by reference to flight instruments are basic elements of airmanship, the Safety Board believes that the FAA and the airline industry should consider the circumstances of this accident with a view toward including scenarios of engine failures after establishment of the takeoff climb in training programs to better prepare pilots for such emergencies. Consideration also should be given to reducing pilot reliance on external visual cues during "V1 cut" training by making greater use of simulated low visibility situations during such training.

2.5.4 Crew Coordination

The CVR comments suggest that the captain was uncertain and perhaps confused by the events which immediately followed the failure of the right engine. He had never experienced an in-flight engine failure on a DC-9, and he had not heard the sounds associated with such a failure in his flight simulator training. The yaw and deceleration motion cues he felt in the airplane also would have been slightly different from the ones to which he had been exposed in his simulator training. His first question to the first officer ("What the # was that?"), may have been rhetorical; however, the Board believes that the captain was requesting assistance. His second question ("What do we got here, Bill"?), occurred 3 seconds after the right engine failure and affirms the concern and uncertainty expressed in his first question. The quality of the CVR recording, both in volume and clarity, leaves little doubt that the first officer heard the captain.

FAA-approved Midwest Express procedures indicate that the first officer should have responded, if able, to the captain's questions because an emergency condition existed and all crewmembers were required to bring to the attention of the pilot-in-command any occurrence which might affect the safety of flight. If the first officer recognized the nature of the emergency, he should have responded to the captain's request for information. Failing to respond may have further confused the captain and that confusion apparently precipitated an improper control response when the airplane was in a critical phase of flight.

The less explicit and unwritten "silent cockpit" philosophy (not making unnecessary callouts or even verbalizing the nature of an emergency after 100 knots and before reaching 800 feet on takeoff) may have influenced the first officer not to respond. However, the Safety Board believes it is more probable that the first officer also was confused by the indications he observed and heard following the engine failure. Nevertheless, the Board is concerned about the contradiction in written and verbal policy at Midwest Express which may have resulted in poor coordination between the two pilots aboard flight 105.

Analysis of the flight track and FDR information reveals that a left deflection of the rudder was commanded

properly, and, perhaps reflexively in response to a perceived heading change or yaw. However, the captain still asked his first officer what was the nature of the occurrence after correct rudder pedal pressure had been applied. Therefore, the captain reflected uncertainty and perhaps confusion after the correct rudder pedal pressure had been applied. Consequently, there was a delay in making a coordinated response to the engine failure, and the captain was uncertain that he had responded correctly. The captain's uncertainty, combined with the failure of the first officer to respond to potentially confusing engine instrument indications, and the absence of outside visual reference may have prompted the captain to remove the force from the left rudder pedal and to introduce forces to the right rudder pedal a few seconds later.

The captain may have asked the first officer for assistance, in part, because of the seniority of the first officer to the captain and because of the first officer's check airman status. The captain would have been justified in expecting that a check airman might be more knowledgeable or more capable than himself in identifying the nature of the problem. The first officer's response to Milwaukee Tower 8 seconds after the right engine failure, which was in conflict with the "silent cockpit" philosophy, was provided in lieu of responding to the captain's questions and occurred when the airplane was yawing to the right, was in a sideslip, and was on the verge of a loss of control. Callouts of memory items from the emergency check list would have been appropriate in response to the engine failure, and also would have been important if a dual engine failure was perceived. If either pilot had initiated the emergency checklist, the nature of the emergency might have been made immediately clear to the other pilot and coordinated crew response might have followed. Also, if a dual engine failure was perceived, a callout to that effect was required by Midwest Express procedures.

A possible explanation for a delay in recognizing the problem is that, instead of coordinating their actions, the captain and the first officer both had shifted to an outside scan to look for other traffic after gear retraction and neither was monitoring flight instruments at the moment of right engine failure. Another possible explanation related to instrument scanning is that the flightcrew shifted their attention collectively to the engine instruments and were not monitoring flight instruments for several crucial seconds between the time correct rudder was initially applied and the time of stickshaker activation. About 6 seconds after the engine failed, the captain said "Here..." but was interrupted by the first officer's response to Milwaukee Tower. The captain may have been pointing out instrument indications associated with the right engine failure, or instrument indications relevant to the left engine power loss, and he may not have been monitoring flight instruments during the brief but critical period.

It is possible that the captain (or the first officer) reacted to the left engine instrument movement. When the right engine failed, the right engine instruments probably reached a steady state condition in a very short time compared to the left engine instruments which decelerated more slowly. The Safety Board considered it plausible that the pilot's attention may have been directed to the movement of the left engine instruments after the right engine instruments became static. If he perceived that the left engine was the problem, he may have reacted to that perception by applying the rudder correction for a left engine failure rather than continuing with the rudder deflection appropriate for a right engine failure.

The attentiveness of the crew to flight instruments during the emergency and a coordinated response to the indications were critical to maintaining control because a swept wing airplane, such as the DC-9, when in a sideslip, will tend to roll unless corrective action is taken. Either the sideslip must be reduced by appropriate rudder deflection or the lateral controls must be deflected to counter the rolling tendencies. The rolling tendency due to sideslip will increase as the lift on the wings increases. For a given G load (lift) and sideslip angle, a certain amount of lateral control deflection will be required to counter the roll. As the G load increases, additional lateral control deflection will be required to counter the roll. In this case, elevator control input caused the G load to increase from about 0.3 Gs to about 1.8 Gs from the 5th to the 11th second.

In the presence of the sideslip angle and increasing acceleration load, the lateral control deflection would have to be approximately doubled to maintain a constant bank angle. If the pilot established a lateral control deflection at the

fourth to fifth second to compensate for the sideslip angle and then was not monitoring the roll attitude as the G load increased, the airplane would roll further to the right. The data indicate that by the time the stickshaker came on, the airplane was in a significant roll attitude to the right and the positive G load was increasing. All of the above conditions should have been evident to the flightcrew by reference to the flight instruments.

The captain, had the individual ability and the responsibility to scan the instruments and to take corrective action. However, an appropriate coordinated flightcrew response also would involve actions by the first officer to assist the captain in diagnosing and responding to the problem. The redundancy provided by the first officer is one of the basic tenets of cockpit resource management.

2.5.5 Cockpit Resource Management

The investigation revealed that Midwest Express did not have a formal training program in cockpit resource management, which is also known as crew coordination. However, the Safety Board believes that with a low pilot to supervisor ratio, the airline could, and probably did, monitor closely the performance of its crewmembers, both as pilots and as individuals participating in the joint operation of flights. Thus, the airline would have been able to assess, to some degree, the extent to which its flightcrew members were effective in working together with other pilots to manage and operate the aircraft effectively.

The Safety Board believes that cockpit resource management is of critical importance to air safety and has urged the FAA to implement formal programs to improve flightcrew coordination. As a result of its investigation of an accident involving a charter flight in Reno, Nevada, ²⁹ the Board recommended that the FAA:

A-86-19

Provide, to all operators, guidance on topics and training in cockpit resource management so that operators can provide such training to their flightcrew members, until such time as the FAA's formal study of the topic is completed.

In its August 25, 1986, response, the FAA indicated concurrence with the recommendation. The FAA reported that they are disseminating information to air carriers that addresses coordination and procedural interaction among pilot crewmembers. Several air carrier operations bulletins and FAA Order 8430.6C, the Air Carrier Operations Inspectors Handbook, contain guidance to FAA personnel in implementing crew coordination. The FAA acknowledged that cockpit resource management included not only procedural interaction between crewmembers, but also subtle and intangible interaction as well. The FAA has contracted with the Aviation Psychology Laboratory of Ohio State University to provide a formal study, of the subtle and intangible interaction aspects of cockpit resource management. The study is scheduled for completion in November 1987. The FAA reported that the anticipated study would serve as a foundation for a future advisory circular and would be a model for industry use. Pending the results of the FAA study, the Safety Board has classified the recommendation as "Open--Acceptable Action."

The Safety Board is a strong advocate of formalized cockpit resource management training. However, the Safety Board is aware that few operators at this time are conducting formal, in-depth training in cockpit resource management techniques and that the FAA has not, as yet, made this a requirement for operators. Midwest Express did not violate FAA rules or practices by not conducting formal training on the subject.

The Safety Board believes that training in emergency procedures should be so thoroughly indoctrinated in training that crew reaction should be prompt and reflexive after an engine failure emergency has been accurately identified. The actions of the flying pilot, in response to the emergency, should be closely monitored by the nonflying pilot, and the nonflying pilot should be monitoring instruments in support of the flying pilot to ensure prompt and correct

response, in accordance with published emergency procedures. Takeoff emergencies typically are critical operations because of low altitude and low speed at their outset. Even though the initial response of the flying pilot may be reflexive, involvement by the nonflying pilot is essential to a proper crew response to the emergency.

In this accident, the cockpit voice recorder revealed the absence of emergency callouts from either pilot and no response from the first officer when the captain requested assistance. Because the first officer responded to Milwaukee Tower, it is clear that he was not incapacitated. However, his failure to communicate with the captain and his possible misjudgment of the seriousness of the situation may have led to an uncoordinated crew response to the emergency. The Safety Board believes that a breakdown in crew coordination was a significant factor in the accident.

2.6 FAA Surveillance and Oversight

2.6.1 Midwest Express Airlines

The Safety Board believes that the FAA oversight of Midwest Express procedures and training during certification and ongoing day-to-day activity in the carrier's first 2 years of operation was less than optimum and probably suffered as a direct result of the inexperience of the POI. The POI testified that she devoted only 20 percent of her worktime to Midwest Express, her only FAR 121 scheduled passenger airline, and that she was still obligated to perform routine general aviation duties. The Board noted that the POI had no previous FAR 121 air carrier experience, that she was not rated in a turbojet of the category and class used by the airline, and that she had not received any formal training in the DC-9 airplane used by the certificate holder for which she was responsible. In fact, she had no turbojet pilot experience. Neither did the POI have available for consultation or assistance air carrier inspectors or DC-9 rated pilots in her own office. Although the POI used the services of air carrier inspectors assigned to other offices to fulfill her responsibilities, it is apparent that this practice reduced her exposure to the operation of the airline. Apparently, she had become so dependent on other inspectors in surveilling Midwest Express that her own role was reduced primarily to administrative matters. The absence of first-hand knowledge of the carrier and her lack of experience in turbojet air carrier operations severely handicapped her ability to perform the quality of surveillance required to detect shortcomings of a FAR 121 airline operation. The Safety Board believes that the experience level of the POI was inappropriate for her assignment as the POI of a new air carrier operating turbojet equipment. She even testified that she was not totally comfortable with the arrangement.

The Safety Board also is concerned that the POI's lack of proper experience may have been a factor which allowed a "silent cockpit" concept to be taught in training even though it was contrary to the approved practice that required any crewmember noting a potential or actual emergency situation to call it to the captain's attention. The Safety Board believes that the latter concept is sound and assures that all flight crewmembers are provided the opportunity to coordinate their activities, to assure the proper resolution of an emergency condition consistent with the practices of most operators of turbojet equipment. Midwest Express employees had discussed the silent cockpit concept with the POI but had not put it in writing or requested her approval of the concept. The Safety Board believes that if the POI had been more experienced she might have recognized the flaws in such a concept, and perhaps she might have recognized that the airline was already teaching the concept in their pilot training program.

The Safety Board supports the latest efforts of the FAA through Project SAFE (Safety Activity Functional Evaluation) to alleviate substandard surveillance of the airline industry. SAFE will revise the position description and qualification criteria for prospective air carrier inspector personnel to insure that the ability of the inspector personnel who would be assigned to a FAR 121 certificate holder matches the job requirements. The FAA targets

its implementation of this plan for fiscal year 1988. The Safety Board believes that the FAA should, as an interim measure, discontinue the practice of assigning FAR 121 air carrier operating certificates to POIs without the training and experience commensurate with the POI role and without a type rating in a comparable (i.e., turbojet powered transport category) aircraft in the category and class used by the certificate holder. The Safety Board noted that the Midwest Express certificate was reassigned to the Air Carrier District Office in Chicago, Illinois, following the Safety Board's public hearing. The Safety Board trusts that if the FAA has not already done so, a review will be undertaken to require that all FAR 121 certificates are overseen by FAA personnel thoroughly knowledgeable in FAR 121 operations.

2.6.2. AeroThrust Corporation

The Safety Board found that Pratt & Whitney's visits to Aero Thrust revealed a number of deficiencies, many of which were not necessarily safety-related, but were related to plant efficiency. Many of the deficiencies, including safety-related items, such as improper test equipment calibration, reportedly were promptly corrected. Also, the training records for the inspector who had last inspected the right engine 9-10 spacer did not reveal the manner in which the inspector was qualified to operate the inspection equipment. Neither did they reflect the results of the inspector's required annual eye examinations. FAA surveillance had not detected the test equipment calibration deficiencies, training record deficiencies, or the apparent lack of required vision testing of AeroThrust inspectors.

The right engine fractured spacer pieces, which were examined in the Safety Board Materials Laboratory, revealed cracks between bleed air holes which contained nickel deposits. This finding indicates that these cracks existed at the time the spacer was last inspected since nickel deposits are introduced during NiCd replating of the spacer. The AeroThrust Corporation (A.C.E.S. in 1981) work order for the spacer showed that the NiCd plating had been stripped from the part during its rework and that the part was free of cracks. The Safety Board believes that cracks were present at the time of the inspection and should have been detectable using FMPI methods. However, the Board does not believe that these cracks precipitated the rupture of the spacer.

Testimony by Pratt & Whitney representatives revealed that the most common failure mode of high pressure compressor spacers involved cracks which were initiated by the knife edge rubbing against the stationary seal land. Fatigue cracks would propagate through the knife edge and pedestal (which supported the knife edge) and then into the spacer barrel until the spacer ruptured. Examination of the failed 9-10 spacer disclosed evidence that cracks had probably initiated in the knife edge and propagated to failure after entering the spacer barrel. The exact origination point could not be identified because the knife edge and part of the pedestal were abraded away, probably during the rupture and ejection of the spacer from the engine. Crack growth data showed that the number of cycles required for a 10-mil crack to propagate to failure (almost 21,000 cycles) were much more than the number of cycles recorded on the engine subsequent to the overhaul (2,584 cycles). Therefore, the originating crack which existed at the time of the spacer overhaul should have been much longer than a 10-mil length and should have been detectable during the 1981 spacer overhaul.

The Safety Board believes that a thorough inspection of the spacer at the time of the 1981 spacer overhaul should have revealed the crack(s) and prevented the subsequent failure of the spacer. Since AeroThrust did not maintain records showing how the Magnaflux inspector was trained or recurrently qualified and it did not have records of the inspector's required annual vision checks, the Safety Board was unable to resolve whether the inspector's training, proficiency, or vision was responsible for his failure to discover cracks during the 1981 inspection of the 9-10 spacer. The Safety Board believes that engine overhaul facilities should document accurately the training of its key inspector personnel and that FAA PMIs should not allow deficiencies in inspector qualification and training records to exist, as they did at A.C.E.S. and AeroThrust Corporation.

The Safety Board found that the PMI assigned to AeroThrust at the time of the accident had been responsive to

deficiencies noted at AeroThrust and that FAA surveillance had increased significantly since his assignment to that certificate in 1985. The Board is concerned, however, that earlier documented FAA surveillance did not identify calibration equipment deficiencies and training record deficiencies which apparently had existed for years at AeroThrust. The Board believes that jet engine repair facilities require more surveillance and guidance from the FAA than was provided to AeroThrust (A.C.E.S.) in 1980-1981 and, therefore, that FAA surveillance of AeroThrust was deficient during that period. The Board concludes that increased FAA surveillance should yield stricter adherence to establish procedures, improved training and recordkeeping, and would, in the future, produce a more capable repair station inspector workforce.

2.7 Removable Sleeve Spacer Fractures

As a result of the Midwest Express accident and a series of incidents which involved the failure of removable sleeve spacers in high pressure compressors of JT8D engines, on November 8, 1985, the Safety Board recommended that the FAA:

A-85-120

Issue an Airworthiness Directive (AD) to require the installation of the one-piece, integral sleeve spacer at all six locations in the high-pressure compressor rotor of Pratt & Whitney JT8D-series engines not so equipped. The installation should be made as soon as practical but not later than the next opportunity wherein the engine is available in the maintenance facility where a partial or complete disassembly of the compressor can be accomplished.

On January 2, 1986, the FAA published a Notice of Proposed Rulemaking (NPRM) in which it proposed to issue an AD that would require:

1. A one-time, on-wing, eddy current inspection of stages 7-8, 8-9, and 9-10 HP compressor removable sleeve spacers in accordance with Pratt & Whitney Alert Service Bulletin (ASB) No. 5649;
2. Replacement of stages 7-8 and 9-10 stage removable sleeve spacers at next HP compressor rotor disassembly within the next 2 years or 4,000 cycles, whichever is later; and
3. Replacement of the 8-9, 10-11, 11-12, and 12-13 stage removable sleeve spacers with integral sleeve spacers, whenever the HP compressor is disassembled.

On February 18, 1986, the Safety Board commented on the NPRM, recommending that the 7-8 and 9-10 stage removable sleeve spacers be replaced as soon as practical--that is, the next time the engine was in a maintenance facility in which the compressor could be partially or completely disassembled, but not later than 4,000 cycles time-in-service from the effective date of the AD.

The Safety Board's comments were based on its understanding that the on-wing eddy current inspection could detect a crack in the pedestal of the spacer just below the knife edge seal and that an existing crack, undetected by the inspection, would therefore take at least 8,000 cycles to propagate through the pedestal and into and across the barrel of the spacer. However, the Safety Board was subsequently informed by Pratt & Whitney that the on-wing inspection would not necessarily detect a crack until it had propagated almost into the spacer barrel, at which time fracture of the spacer could occur in about 1,000 cycles.

The Safety Board was concerned that the 4,000 cycles, or 2 years, whichever was longer, provided by the proposed AD would not adequately protect against additional spacer ruptures and possible damage to vital components of

airplanes. As a result of these concerns and other considerations, the Safety Board concluded that the on-wing eddy current inspection required by the proposed AD and set forth in Pratt & Whitney Alert Service Bulletin (ASB) No. 5649 must be repeated at 1,000-cycle intervals until stage 7-8, 8-9, and 9-10 removable sleeve spacers within the engine have been replaced with one-piece integral sleeve spacers. Consequently, on April 7, 1986, the Safety Board recommended that the FAA:

A-86-28

Issue a Telegraphic Airworthiness Directive and amend the airworthiness directive proposed in the Notice of Proposed Rulemaking published at 51 FR 37, Docket No. 85-ANA-46, to require that the one-time, on-wing eddy current inspection specified in the proposed airworthiness directive be repeated at 1,000-cycle intervals until stage 7-8, 8-9, and 9-10 removable sleeve spacers between the high-pressure compressor are replaced with integral sleeve spacer.

As a result of its issuance of Safety Recommendation A-86-28 which updated the Safety Board's concerns about JT8D removable sleeve compressor spacers, Safety Recommendation A-86-120 was classified as "Closed--Superseded."

On May 13, 1986, the FAA issued Airworthiness Directive (AD) 86-08-04 which requires eddy current inspection and subsequent replacement of high pressure compressor (HPC) removable sleeve spacers on certain JT8D engines. Although, the AD was responsive to the intent of Safety Recommendation A-85-120, it was not fully responsive to the concerns expressed to the FAA in Safety Recommendation A-86-28. The Safety Board has learned that the FAA declined to modify AD-86-08-04 as recommended by the Board. The Safety Board takes exception to the FAA's position that repetitive eddy current inspections are not necessary. In the Board's opinion, eddy current inspections should be repeated at 1,000-cycle intervals until the subject removable sleeve compressor spacers are removed from service. The Safety Board has classified Safety Recommendation A-86-28 as "Closed—Unacceptable Action," but will continue to voice its concerns should additional failures of removable sleeve spacers continue. The Safety Board remains convinced that prompt replacement of removable sleeve compressor spacers in JT8D engines, with integral sleeve spacers, is the best solution to the spacer rupture problem.

2.8 Flight Data Recorder

The Safety Board has repeatedly expressed views that the flight data recorders of the U.S. airline fleet are not totally adequate for accident investigation purposes. N100ME was equipped only with a five parameter metal foil analog FDR, as are most other turbojet transports for which type certificates were issued before September 30, 1969, even though they may have been manufactured and introduced into the fleet more recently. Consequently, the Safety Board was deprived of data regarding the airplane's engine performance, flight control positions, inertial attitudes, and accelerations, all of which would have provided information essential to support the theoretical analysis of the factors leading to the airplane's departure into an uncontrollable descent. The Safety Board was able to determine engine thrust level, a key element in the accident analysis, from the engine sounds recorded on the airplane's CVR. However, this was fortuitous in this investigation since engine sounds are seldom discernible on the CVR in those airplanes with aft fuselage mounted engines. Engine thrust data, as well as the flight control and inertial data required for a more comprehensive analysis of this accident are required to be recorded on the digital FDRs installed on airplanes certificated after September 30, 1969.

In recognition of the shortcomings of the FDRs required on the earlier type-certificated airplanes, the Safety Board on July 13, 1982, issued Safety Recommendations A-82-64 through -66 to the FAA:

A-82-64

Amend 14 CFR 121.343 so that, after a specified date, all turbojet aircraft manufactured before that date and type-certificated before September 30, 1969, be required to have installed a suitable digital recorder system capable of recording data from which the minimum following information may be determined as a function of time within the ranges, accuracies, and recording intervals specified in Table I--altitude, airspeed, heading, radio transmitter keying, pitch attitude, roll attitude, vertical acceleration, longitudinal acceleration, stabilizer trim position, engine thrust, and pitch control position.

A-82-65

At an early date and pending the effective date of the recommended amendment of 14 CFR 121.343 to require installation of digital flight data recorder systems capable of recording more extensive parameters, require that operations of all aircraft equipped with foil flight data recorders be required to replace the foil recorder with a compatible digital recorder.

A-82-66

Amend 14 CFR 121.343 so that, after a specified date, all aircraft manufactured after that date, regardless of the date of original type certificate, be equipped with one or more approved flight recorders that record data from which information listed in Table I can be determined as a function of time. For newly type-certificated aircraft, any dedicated parameter which may be necessary because of unique features of the specific aircraft configuration and the type design should also be required.

On January 8, 1985, the FAA issued a Notice of Proposed Rulemaking, the substance of which proposes retrofit of digital type recorders with added parameters on all transport airplanes not so equipped. Although the Safety Board believes that requirements even more stringent than those proposed are needed, the Board supported the proposed rulemaking and acknowledged that it would be a significant step toward improving flight recorder standards. The Board is very concerned that 2 years have passed since the initiation of the rulemaking action and a final rule is yet to be adopted.

The Safety Board further notes that the aviation regulatory authorities of other countries progressive in the aviation field have adopted FDR requirements more stringent than those required or even proposed by the FAA. In face, the International Civil Aviation Organization (ICAO) has adopted standards which are consistent with Safety Board recommendations. The Safety Board will continue to urge the FAA to expedite the rulemaking actions to upgrade flight recorders on the U.S. airline fleet and to ultimately require that new airplanes be equipped with recorders which met ICAO standards.

Pending further FAA action, Safety Recommendations A-82-64 through -66 have been classified as "Open-Acceptable Action."

3. Conclusion

3.1 Findings

1. The flightcrew was medically and operationally qualified and well rested before the flight. There was no indication of chronic or life event stress-related factors which would have affected the performance of either pilot.
2. N100ME was certified, equipped, and maintained in accordance with FAA rules. There were no uncorrected discrepancy reports which involved powerplants or control systems.
3. N100ME was dispatched within the applicable weight and center of gravity limitations.
4. The aircraft performance was normal during the takeoff and initial climb phases of flight until the right engine failed at 450 feet a.g.l. at a speed well in excess of the takeoff safety speed (V2).
5. The right engine failed abruptly and completely due to the uncontained failure of the 9th to 10th stage high pressure compressor spacer.
6. Uncontained pieces of the ruptured spacer did not cause any significant damage to the airplane fuselage, control systems, or the left engine.
7. The right engine failure was precipitated by a fatigue crack in a knife edge of the 9th to 10th stage spacer. The crack had propagated to a length which should have allowed detection on the occasion of the last high pressure compressor overhaul and spacer rework in 1981.
8. None of the airplane flight control systems were disabled.
9. The cause of the left engine power loss, which occurred beginning about 1.5 seconds after the right engine failed, was not determined.
10. The left engine experienced a compressor stall in the last seconds of the flight after control had been lost and the airplane was descending toward the ground in an unusual attitude.
11. The loss of left engine power was not significant with respect to the loss of control of the airplane.
12. The captain initially responded correctly with deflection of the rudder pedal to the left to compensate for the loss of right engine thrust and by lowering the nose of the aircraft; however, he appeared to be unaware of the exact nature of the emergency.
13. The crew response to the right engine failure was not coordinated.
14. Neither pilot verbally identified the emergency condition or made the emergency callouts required by FAA-approved Midwest Express procedures.
15. The rudder was incorrectly deflected to the right 4 to 5 seconds after the right engine failure.
16. An accelerated stall and loss of control occurred 10 seconds after the failure of the right engine.
17. Forward visual cues (outside the cockpit) were not available to the crew at the time that the

right engine failed. Peripheral visual cues were available.

18. The visual flight simulator, which was used by the crewmembers in training, did not provide onset yaw and longitudinal acceleration cues, peripheral visual cues, or aural cues which were available to the crew in the airplane.
19. The captain and first officer misinterpreted the inside visual cues which were presented in the airplane.
20. The differences in visual motion and aural cues presented in the visual flight simulator and in the airplane may have limited the ability of the flightcrew to recognize and react appropriately to the emergency.
21. Failure to recognize the nature of the emergency and improper operation of flight controls precipitated the loss of control.
22. The DC-9-14 does not require unusual pilot skill or strength to maintain continued flight following an engine failure on takeoff.
23. Both crewmembers were relatively inexperienced in DC-9 flight operations.
24. The FAA Principal Operations Inspector who was responsible for oversight of Midwest Express was inexperienced in FAR 121 turbojet air carrier operations.
25. A "silent cockpit" philosophy was suggested by Midwest Express in response to certain emergency situations, although the concept was not approved by the FAA and was in conflict with approved emergency procedures.
26. FAA surveillance of Air Carrier Engine Service (Aero Thrust) was deficient in the 2-year period which preceded the overhaul of the 9-10 spacer.
27. The accident was nonsurvivable because the impact forces exceeded the limitations of human tolerance.

3.2 Probable Cause

The National Transportation Safety Board determines that the probable cause of the accident was the flightcrew's improper use of flight controls in response to the catastrophic failure of the right engine during a critical phase of flight, which led to an accelerated stall and loss of control of the airplane. Contributing to the loss of control was a lack of crew coordination in response to the emergency. The right engine failed from the rupture of the 9th to 10th stage removable sleeve spacer in the high pressure compressor because of the spacer's vulnerability to cracks.

4. Recommendations

On November 8, 1985, the Safety Board recommended that the Federal Aviation Administration:

A-85-120

Issue an Airworthiness Directive (AD) to require the installation of the one-piece, integral sleeve spacer at all six locations in the high-pressure compressor rotor of Pratt & Whitney JT8D-series engines not so equipped. The installation should be made as soon as practical but no later than the next opportunity wherein the engine is available in the maintenance facility where a partial or complete disassembly of the compressor can be accomplished.

A-85-121

Notify appropriate foreign civil aviation authorities and foreign operators of airplanes equipped with Pratt & Whitney JT8D-series engines of the failures associated with the removable sleeve spacers installed in the high-pressure compressor rotor and of the actions which should be taken to minimize or eliminate the failures.

On April 7, 1986, the Safety Board recommended that the Federal Aviation Administration:

A-86-28

Issue a Telegraphic Airworthiness Directive and amend the airworthiness directive proposed in the Notice of Proposed Rulemaking published at 51 FR 37, Docket No. 85-ANA-46, to require that the one-time, on-wing eddy current inspection specified in the proposed airworthiness directive be repeated at 1,000-cycle intervals until stage 7-8, 8-9, and 9-10 removable sleeve spacers between the high-pressure compressor are replaced with integral sleeve spacers.

As a result of its investigation, the Safety Board recommended that the Federal Aviation Administration:

Issue an air carrier operations bulletin directing Principal Operations Inspectors to review their respective air carrier's flightcrew training programs to ensure the existence of new coordination procedures that, notwithstanding a policy endorsing nonessential conversation during an emergency condition, require any crewmember who observes a potential or actual emergency situation to verbally call it to the captain's attention. (Class II, Priority Action) (A-87-8)

Issue an air carrier operations bulletin directing Principal Operations Inspectors to review their respective air carrier's simulator training programs to verify that engine failures in the posttakeoff climb are frequently given with particular emphasis on the use of engine and flight instruments as the primary source of information for airplane control and on the need for deliberate actions based upon flight and engine instrument analysis rather than hasty action based upon kinesthetic cues. (Class II, Priority Action) (A-87-9)

Require Principal Operations Inspectors of 14 CFR 121 certificate holders to have training and experience commensurate with the air carrier involved, including a comparable type rating (e.g., turbojet powered transport category) in the category and class of aircraft to be used by the certificate holder. (Class II, Priority Action) (A-87-10)

BY THE NATIONAL TRANSPORTATION SAFETY BOARD

JIM BURNETT
Chairman

PATRICIA A. GOLDMAN
Vice Chairman

JOHN K. LAUBER
Member

JOSEPH T. NALL
Member

Jim Burnett, Chairman, filed the following dissenting statement regarding probable cause and contributing factors:

The probable cause of the accident was the catastrophic failure of a high pressure compressor spacer in the right engine during a critical phase of flight, together with the flightcrew's improper use of the flight controls that resulted in an accelerated stall and loss of control of the airplane.

Contributing to the cause of the accident was a training program which inadequately prepared the flightcrew to diagnose and respond to an engine-out situation in the climb-out phase of flight, a lack of crew coordination in response to the emergency, and the inadequate inspection of the compressor spacer at the engine repair facility.

JIM BURNETT
Chairman

February 3, 1987

5. Appendixes

Appendix A Investigation And Hearing

1. Investigation

The National Transportation Safety Board was notified of the accident about 1645 e.d.t., on September 6, 1985, and immediately dispatched an investigative team to the scene. Investigative groups were established for operations, air traffic control, aircraft structures, aircraft systems, powerplants, survival factors, witnesses, maintenance records, cockpit voice recorder, flight data recorder, human performance, and aircraft performance. In addition, specialist reports were prepared to summarize findings relevant to meteorology, metallurgy, and the sound spectrum examination of the cockpit voice recorder.

Parties to the investigation were the Federal Aviation Administration; Midwest Express Airlines, Inc.; the Douglas Aircraft Company; Pratt & Whitney Aircraft Company; AeroThrust Corporation; and the Milwaukee County Office of Emergency Government.

2. Public Hearing

A 4-day public hearing was held in Milwaukee, Wisconsin, beginning February 18, 1986. Parties represented at the hearing were the Federal Aviation Administration; Midwest Express Airlines, Inc.; the Douglas Aircraft Company;

Pratt & Whitney Aircraft Company; and AeroThrust Corporation.

Appendix B Personnel Information

Captain Danny Watkin Martin

Captain Martin, 31, held airline transport pilot certificate No. 2352484 with a DC-9 type rating and an airplane multiengine land rating. He held a first class airman medical certificate, which was issued March 7, 1985, with no limitations.

First Officer William Roger Weiss

Captain Weiss, 37, held airline transport pilot certificate No. 2125955 with a DC-9 type rating and airplane single and multiengine land ratings. He held a first class airman medical certificate, which was issued August 19, 1985, with no limitations.

Appendix C Standard Noise Abatement Takeoff Procedures

The following standard noise abatement takeoff procedures were applicable to flight 105's takeoff and were contained in the Midwest Express Crew Operating Manual (COM):

1. The pilot sets his heading bug to runway heading as an aid in maintaining directional control in the event of an engine failure after V1.
2. The copilot sets his heading bug to departure heading.
3. After receiving takeoff clearance, both pilots scan engine instruments for abnormal indications.
4. The pilot then advances throttles to takeoff EPR settings, cross-referencing N1 to assure correct EPR settings, keeping one hand on the throttles until V1.
5. The copilot then adjusts throttles to takeoff EPR and by 60 knots calls out "power normal."
6. The copilot calls out "100 knots, "V1," and "Rotate."
7. When positive rate of climb is established, the copilot calls out, "positive rate" after which the pilot calls for "gear up."
8. Void of abnormal circumstances, the pilot climbs the aircraft to 1,000 feet above field level, maintaining at least V2 airspeed and a maximum pitch of 15 degrees up.
9. No turns are to be made below 400 feet above field level (a.f.l.). Above 400 feet a.f.l., maximum bank angle is limited to 15° until reaching best single engine climb speed, with a maximum of 30° bank thereafter. At 1,000 feet above field level or minimum gross level off altitude (MGLO), if higher, pitch was to be decreased to approximately 10° to allow the

airplane to accelerate.³⁰

Appendix D Wreckage Diagram

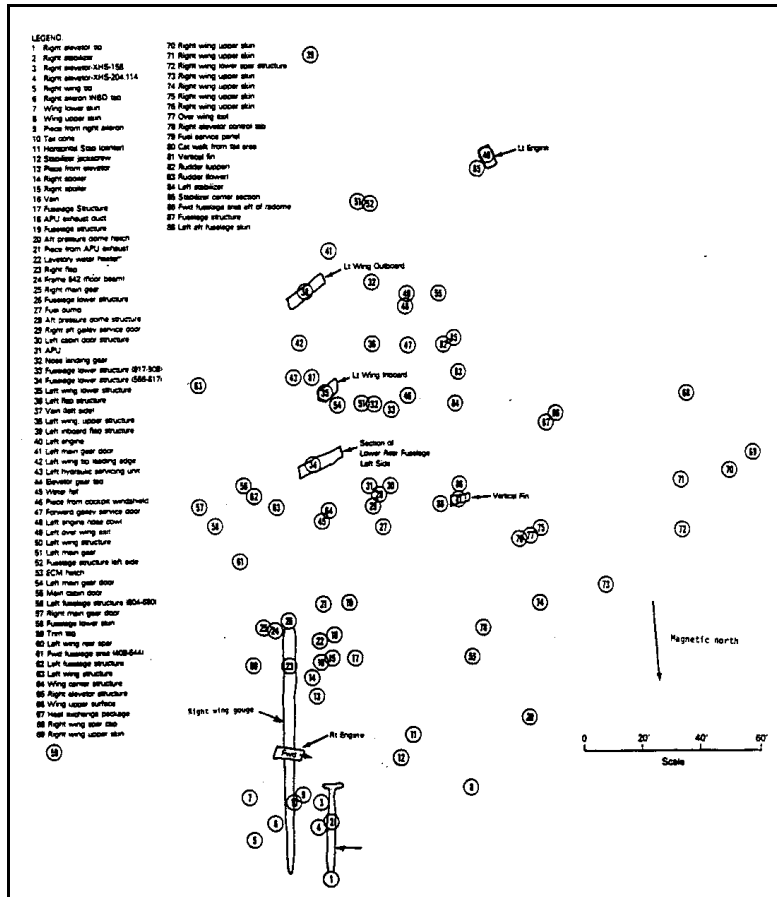

Appendix E Transcript Of Cockpit Voice Recorder

BY JAMES R. CASH AIR SAFETY INVESTIGATOR The reader of this report is cautioned that the transcription of a CVR tape is not a precise science but is the best product possible from an NTSB group investigative effort. The transcript, or parts thereof, if taken out of context, could be misleading. The attached CVR transcript should be viewed as an accident investigation tool to be used in conjunction with other evidence gathered during the investigation. Conclusions or interpretations should not be made using the transcript as the sole source of information.

August 27, 1986

Errata To Group Chairman Factual Report Of Investigation Cockpit Voice Recorder Dca 85-A-A036

A. Accident

Location : Milwaukee, Wisconsin

Date : September 6, 1985

Aircraft : Midwest Express Airlines, Inc., Flight 105 (MEP/105),
McDonnell Douglas DC-9-14, RN:100ME, SN:47309

B. Group

Not applicable.

C. Details Of Investigation

Errata

The following changes should be made to the "Group Chairman's Factual Report of Investigation Cockpit Voice Recorder," dated September 25, 1985.

Cover Sheet

Change second line of title from "COCKIT VOICE RECORDER" to "COCKPIT VOICE RECORDER."

Page 2

Second paragraph, line 4 - change time "15:21:04" to "15:20:43."

Page 5 (of transcript)

Change time "17:17:46" to "15:17:46."

James R. Cash
Air Safety Investigator

September 25, 1985

Group Chairman Factual Report Of Investigation Cockpit Voice Recorder

A. Accident

Location : Milwaukee, Wisconsin
Date : September 6, 1985
Aircraft : Douglas DC-9, N100ME
Operator : Midwest Express Airlines
Flight No. : 105
NTSB No. : DCA 85-A-A036

B. Group

James R. Cash, National Transportation Safety Board, Chairman
Paul H. Oldale, McDonnell Douglas Aircraft Company, Member
Gary Drska, Midwest Express, Member
Rick L. Cremer, Federal Aviation Administration, Member

C. Summary

A badly damaged Fairchild model A-100 cockpit voice recorder (CVR), S/N 875 was brought to the Audio Laboratory of the National Transportation Safety Board. The recording medium was undamaged and a transcript was prepared (attached) from engine start until the end of the recording.

D. Details Of Investigation

The cockpit voice recorder case sustained both physical and fire damage during the accident and the post crash fire. The dust cover that covers the whole unit was severely crushed and had to be cut off. The impact protection case

had all five of the retaining bolts sheared off. The front panel, including the data plate was not recovered with the rest of the CVR unit. The electronic circuit boards and the internal wiring of the CVR were severely burned and melted. The recording media inside of its fire protection suffered no damage. The tape was not broken and the reel assembly was intact. The tape was moist but suffered no permanent damage.

The overall quality of the recording was good. All of the cockpit voice recorder channels were working. The No. 1 channel of the CVR, which is normally associated with the flight engineer's radio panel, was connected to the aircraft's passenger intercom. At 15:20:41.7 CDT, all of the CVR channels got approximately 30 percent louder in volume than they had been during the preceding 30 minutes. This louder volume continued until 15:21:26.4 CDT, when the volume of all of the CVR channels returned to the lower level. This change in volume, because it effected all the CVR channels equally, is probably associated with some type of internal short or loose wire internal to the CVR unit, and not associated with any other aircraft systems. The recording was approximately 32 minutes in length, but only the last 7 minutes were transcribed. The information contained in this beginning 25 minutes consisted of casual conversation with the flight attendants, and the flight attendants briefing by the captain. The before start engine checklist items were also accomplished in accordance with company procedures and company operating manuals during this time.

The transcript began at approximately 15:14:33 CDT with the start of the number two engine. The aircraft started to taxi at approximately 15:16:22 CDT. The flight was cleared for takeoff at 15:20:29 CDT, and the power was heard to increase at 15:21:04. The takeoff appeared normal until 15:21:26.4 CDT when a loud clunk sound was heard, followed by a noticeable decrease in the sound of one of the engines. The stall warning stickshaker came on at 15:21:36.0 CDT and continued until the end of the recording. The power was interrupted to the cockpit voice recorder at 15:21:38.8 for only 0.1 second. At 15:21:41.7, two-tenths of a second before the end of the recording, the sound of the start of the "whoop whoop" warning of the ground proximity warning system could be heard. The end of the recording occurred at 15:21:41.9 CDT.

James R. Cash
Air Safety Investigator

TRANSCRIPT OF A FAIRCHILD A-100 COCKPIT VOICE RECORDER S/N 875, REMOVED FROM THE DC-9, N100ME, WHICH WAS INVOLVED IN AN ACCIDENT AT MILWAUKEE, WISCONSIN, ON SEPTEMBER 6, 1985

LEGEND

CAM	Cockpit area microphone voice or sound source
RDO	Radio transmission from accident aircraft
INT	Intercom transmission from accident aircraft
-1	Voice identified as Captain
-2	Voice identified as First Officer
-3	Voice identified as No. 1 Flight Attendant
-?	Voice unidentified
UNK	Unknown
TWR	Milwaukee Local Tower Control
GND	Milwaukee Ground Control
GCRE W	Ground Crew
GPWS	Ground proximity warning system
*	Unintelligible word
#	Nonpertinent word
%	Break in continuity
()	Questionable text
(())	Editorial insertion
---	Pause

TIME & SOURCE	CONTENT	TIME & SOURCE
15:14:33		
CAM-1	Starting number two Bill	
15:14:53		
CAM	((Sound of engine spooling up))	
		15:15:05
		GCREW
15:15:08		
CAM	((Sound of power interruption to CVR due to bus transfer during start))	
15:15:38		
CAM	((Sound of engine spooling up))	
		INT-1
		GCREW
15:15:53		
CAM-1	Okay, after start checklist	
CAM-2	Annunciator	
CAM-1	Checked	
CAM-2	Ignition off --- electrical power checked --- gallery power on	
15:15:58		
CAM-2	APU air off --- air conditioning packs auto --- pneumatic cross feed closed --- alternate pump on * checked	
15:16:07		

CAM-1	Okay		15:16:11
		RDO-2	Ground Midex one
			15:16:16
			GND
			15:16:22
			RDO-2
15:16:24			
CAM-1	***		
CAM-2	*		
			15:16:28
			RDO-2
			15:16:31
			GND
			15:16:35
			RDO-2
15:16:44			
CAM-2	Okay flaps are comin' to twenty --- trim is ah two point two		
CAM-1	Set		
CAM-2	Set		
15:16:50			
CAM-2	EPR and airspeed bugs --- one ninety one ---		

CAM-1 Set ---
CAM-2 And ---one thirty three
CAM-1 One ninety one, one thirty three
set ---
CAM-? ***
15:16:59
CAM-1 One ninety one, one thirty three set
and cross check
CAM-2 Set cross check
15:17:13
CAM-2 Flight instruments
CAM-1 One twenty five and slaving
CAM-2 One thirty now and slaving
CAM-1 Correct
15:17:21
CAM-2 Anti skid
CAM-2 * turn right
CAM-1 Okay, you can arm it
15:17:35
CAM-2 Controls and elevator power
CAM-1 Free and checked on the bottom
CAM-2 Free and checked on the top
17:17:46
CAM-2 Engine anti ice and fuel heat
CAM-1 Off, off and not required
15:17:50

CAM-2 Pneumatic cross feeds closed, APU
comin' down, taxi checklist complete

CAM-1 Okay

15:17:56

CAM-1 Standard briefin' Bill ah --- * *
one point nine on the EPR

CAM-2 Okay

CAM-1 ** already can't even talk

15:18:10

CAM-2 Any time you want to, I'll ah take a
leg or whatever

CAM-1 Ah that's all right

15:18:15

CAM-2 I wouldn't mind getting a right seat
landing any how

CAM-1 Okay, ya sure great

15:18:20

CAM-1 Oh what a guy

15:18:26

CAM-1 I'll make sure it's the worst leg ---

CAM-2 Ya right

15:18:36

INT-2

15:18:56

CAM ((Nonpertinent conversation between the captain and first officer concerning topics not relating to aircraft operations))

15:19:06

CAM-1 Oh * flies for that commuter outfit down there --- is that a commuter outfit out of Atlanta

15:19:11

CAM-2 Really, I'm not familiar with ---

15:19:15

CAM-1 I'm ready any time you are

15:19:15

RDO-2

15:19:19

TWR

15:19:23

RDO-2

15:19:27

CAM-1 Before takeoff checklist

15:19:33

CAM-2 Flight attendant signal two bells

CAM ((Sound of two bells))

15:19:31

CAM-2 Transponder on --- flaps twenty

CAM-1 Twenty's checked

CAM-2	Annunciator	
15:19:36		
CAM-1	Checked	
CAM-2	Ignition	
CAM-1	(It's checked)	
CAM-2	Before takeoff check complete	
15:19:39		
CAM-1	Okay	
CAM-2	Semi-final	
15:19:54		
CAM-1	Corporate jet almost looks like a fighter, doesn't it	
15:19:57		
CAM-2	Yeah	
		15:20:29
		TWR
15:20:30.4		
CAM	((Sound similar to parking brake release))	
15:20:31		
		RDO-2
15:20:32.3		
CAM-1	Here we go	
15:20:43		
CAM	((Sound of increasing engine noises))	

CAM-1	Spooling up
15:20:52	
CAM-2	* comin' up
15:20:55.7	
CAM-2	Power normal
15:21:02.4	
CAM-2	One hundred
15:21:07.3	
CAM-2	Vee one
15:21:08.0	
CAM-2	Rotate
15:21:09.7	
CAM	((Sound of thump))
15:21:13.9	
CAM-2	Positive rate
15:21:14.2	
CAM-1	Gear up
15:21:14.4	
CAM	((Sound similar to gear handle being repositioned))
CAM	((Sound similar to nose gear door closing))
15:21:22.3	
CAM	((Sound similar to normal spoiler handle mechanism recycling))
15:21:26.4	
CAM	((Sound of loud clunk))

15:21:26.7

CAM ((Sound similar to engine spooling down))

15:21:27.6

CAM-1 What the # was that

15:21:29.0

TWR

15:21:29.5

CAM-1 What da we got here Bill

15:21:33

CAM-1 Here--

15:21:34.0

RDO-2

15:21:36.0

CAM ((Sound similar to stickshaker starts and continues until end of tape))

15:21:38

CAM-1 Oh #

15:21:39

CAM-3 * heads down

15:21:38.0

TWR

15:21:38.8

CAM ((Sound of power interruption to the CVR for 0.1 second))

15:21:40

CAM-3 Heads down

15:21:40.8

UNK

15:21:41

CAM-3 Heads down

15:21:41.7

GPWS Whoop- ((sound of the beginning of first "whoop" of the ground proximity warning system))

15:21:41.9 ((End of Recording))

Appendix F Correlated Plot Of Flight Data Recorder, Radar Data, Left Engine Thrust Data, And Cockpit Voice Recorder; And Airport Map

National Transportation Safety Board Bureau of Technology, Washington, D.C.

CORRELATED PLOT OF FLIGHT DATA RECORDER, RADAR DATA, LEFT ENGINE THRUST DATA, AND COCKPIT VOICE RECORDER; AND AIRPORT MAP

National Transportation Safety Board
 Bureau of Technology, Washington, D.C.

Location: Milwaukee, Wisconsin Recorder M/M: Fairchild 5424
 Date: September 6, 1985 Recorder S/N: 7279
 Aircraft: Douglas DC-9-14, N100ME Ident. No.: DCA-85-A-A036
 Operator: Midwest Express Airlines, Inc. Report No.: 85-44
 Flt. No.: 105

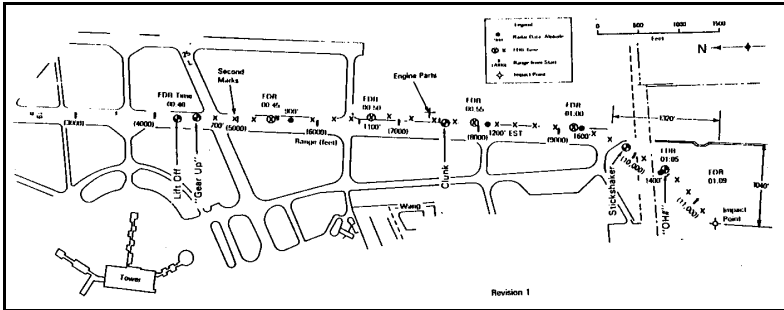
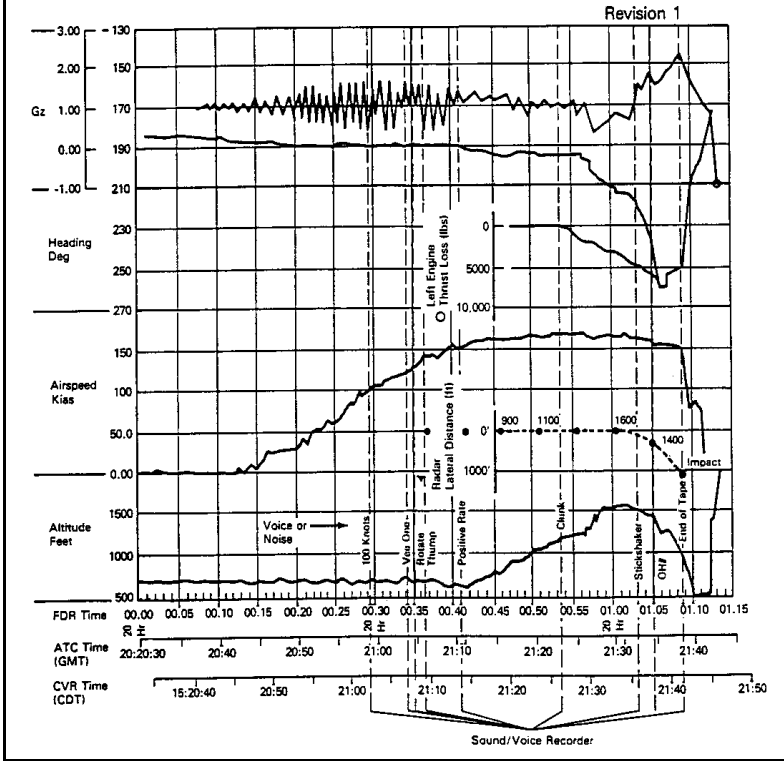

Appendix G DC-9-14 Flight Control System Description

This text was printed from the NTSB Maintenance Accident Report Infobase developed by Galaxy Scientific Corporation with funding from the Federal Aviation Administration Office of Aviation Medicine. Copyright© 1998. All rights reserved.

Lateral Control

Conventional control wheels are cable-connected to control tabs on the ailerons. Aerodynamic forces on the control tabs move the ailerons. An independent cable system connects the control wheels to each aileron control tab individually. Left and right ailerons are bussed together so that they always move together in the proper direction. Each aileron contains a conventional trim tab which is connected by cables to a trim knob on the pedestal.

Aileron lateral control is aided by a flight spoiler system. Aileron control tab cable movement is linked to a mechanical mixer assembly that actuates the flight spoiler hydraulic control valve. The flight spoiler surfaces start to extend after about 5° of control wheel throw. Full aileron deflection is reached when the wheel is deflected about 90°, at which time the spoilers on the appropriate wing are deflected about 30°. The crew can continue to deflect the wheel, stretching the aileron cables, to gain an additional 30° of spoiler deflection. The inner and outer flight spoiler systems are powered by separate hydraulic systems, so that with one hydraulic system inoperative, one-half of the flight spoiler effectiveness is retained.

Directional Control

Conventional rudder pedals control rudder movement. During normal rudder operations, the rudder control tab is locked hydraulically. Rudder pedal movement operates the rudder power control valve through a closed loop cable system. The rudder power control valve hydraulically actuates the rudder power control unit, which is powered by the right hydraulic system. A conventional trim knob on the pedestal repositions the neutral point of the rudder power actuator to provide trim. Hydraulic power to the rudder power unit may be shut off by placing the rudder power control handle in the manual position in the cockpit. When hydraulic pressure drops to about 950 psi, the rudder automatically reverts to manual operation, unlocking the rudder control tab.

During manual rudder operation, rudder pedal movement through control cables operates a control tab on the rudder. Aerodynamic force on the control tab moves the rudder.

The "Q limiter" restricts rudder travel at speeds above 176 knots. Rudder travel is unrestricted below 176 knots. At speeds between 176 and 181 knots, rudder travel is limited to $\pm 18^\circ$. Rudder travel limits are modulated between $\pm 18^\circ$ and $\pm 3 \frac{1}{2}^\circ$ at speeds between 181 and 350 knots. The Q limiter utilizes a bellows, a spring mechanism and a hook to limit the rudder travel, and a pitot tube, which is mounted on the leading edge of the vertical fin, to sense the ram air pressure. Higher speeds cause higher ram air pressure on the bellows, resulting in restriction of rudder movement.

A yaw damper is provided to improve damping of any lateral directional oscillation. Yaw damper operation is selected by a switch on the overhead panel. Although operation of the DC-9-10 series airplane is normally conducted with the yaw damper on, Douglas pilots testified, and Douglas and FAA pilots who participated in a Safety Board's flight demonstration showed, that control of the DC-9 was predictable and did not require exceptional pilot skills with yaw damper off and with one engine shut down. The yaw damper has a limited authority of about 1.6° of deflection with a maximum yaw damper induced rudder deflection occurring at a rate of about 0.66° per second.

The tab on the rudder has a servo arrangement where rudder deflection results in additional tab deflection. If the rudder moves trailing edge right, the tab moves even farther trailing edge right, aerodynamically resisting the rudder travel. This system would resist excessive rudder deflection in the event of a single rudder cable failure.

The primary rudder cable system originates under the cockpit floor and terminates at a control sector at the base of

the rudder. The cables are routed through lightening holes in the floor beams, about 19 inches to the left of the aircraft centerline and 4 inches below the cabin floor. After passing rearward of the aft pressure bulkhead, the cables angle upward toward the aircraft centerline, terminating at the control sector. The sector provides control input to the hydraulic actuators or the aerodynamic control tab.

The rudder trim cables are a closed loop system which originates in the cockpit center console between the pilot seats and terminates at a load feel and trim unit which is attached to the same sector to which the primary cables are attached. The trim cables are routed aft through lightening holes in the floor beams about 10 inches to the right of the aircraft centerline, 4 inches below the cabin floor. Forward of the aft pressure bulkhead, the trim cables are routed outboard and aft, then go vertically up the aft wall of the lavatory. After passing through the aft pressure bulkhead, they are routed to the load feel and trim unit. In the aft fuselage area, both sets of rudder cables are at a lower level than the engine nacelles. The hole in the right engine was forward of the aft pressure bulkhead.

The stainless steel hydraulic system supply lines and the aluminum hydraulic return lines, which go to and from the rudder power unit, are connected to the rudder power shutoff valve just aft of the aft pressure bulkhead. The lines then progress diagonally along the inboard edge of the vertical stabilizer support bulkhead to the hydraulic cylinder.

The rudder power (hydraulic) unit is located behind a large bulkhead just below the bottom of the rudder and in line with the rudder hinge line. The hydraulic lines to the rudder are routed along the right side of the aircraft, several inches inboard of the fuselage skin and then progress upward to the rudder power unit, aft of the aft pressure bulkhead.

Longitudinal Control

The elevator control system is a conventional, cable-operated aerodynamic boost system that operates a single control tab on each elevator. Each control tab is driven by an independent, two-way cable system from the corresponding control column in the cockpit. A bus torque tube connects the two control columns. The primary elevator cable system originates at each control column and terminates at independent control sectors at the inboard end of the corresponding elevator. One cable loop is routed along the left side of the aircraft, paralleling the primary rudder cables, and then continues up the rear spar of the vertical stabilizer to the control sector. The other cable loop is routed through the floor beams approximately 19 inches to the right of the aircraft centerline and 4 inches below the top of the cabin floor. At the aft pressure bulkhead, both cable loops follow the same routing as the rudder trim cables before continuing up the rear spar of the vertical stabilizer to the control sector.

Movement of either control column moves the control tab. Aerodynamic force, generated by the tab, moves the elevator. As each elevator moves, an additional tab, which is geared to elevator movement, moves to assist the control tab. A hydraulically powered augmentor system, which is powered by the left hydraulic system, is provided to assure airplane nosedown capability under extreme high angle of attack flight conditions. The augmentor system consists of two control valves in series and an actuator on each elevator surface. A hydraulic accumulator allows several cycles of elevator operation in the event of loss of hydraulic (left) system pressure. If, during stall conditions, elevator control tab displacement reaches 10° nosedown because the elevator has not responded, the augmentor system will port pressure to apply nosedown elevator. The elevator will then follow the position of the control column.

A horizontal stabilizer provides longitudinal trim. It is moved by an irreversible jackscrew which can be adjusted by use of primary or alternate trim controls. When the horizontal stabilizer is being moved by either trim system, an audible signal is sounded once for each 1/2° of stabilizer movement. A stabilizer takeoff warning switch is cam-operated by the stabilizer position indicator cable to provide an intermittent audible warning if the throttles are advanced for takeoff and the stabilizer is not in the takeoff range.

Flap System

Each flap is actuated by two hydraulic actuators, one mounted inboard and one at the outboard end of the flap. The outboard cylinders are operated by the left hydraulic system. The inboard actuator cylinders are operated by the right hydraulic system. The flaps will operate with the loss of one hydraulic system, but at a reduced rate. A bus tie cable is used to assure symmetrical flap movement.

Stall Warning System

A lift transducer on each wing and a flap position transmitter (for each flap) supply signals to two separate summing units. During approach to a stall, either summing unit may actuate a control column stickshaker stall warning system. The vibration is felt in both control columns, if activated.

Hydraulic Systems

The DC-9 has two independent hydraulic systems, designated left and right. Services normally receiving pressure from both hydraulic systems will operate, but at reduced efficiency when one system is inoperative. Each system has a hydraulic reservoir and an engine-driven hydraulic pump. There are no provisions for routing fluid from one system to the other. An alternate hydraulic motor/pump mechanically connects the two systems. In addition, the right system has an electrically powered auxiliary hydraulic pump. Medium and high pressure hydraulic lines are stainless steel pipe.

The left hydraulic system supplies pressure for operation of the following (partial list):

1. Inboard spoilers;
2. Wing flap outboard actuator;
3. Elevator augmentor power; and
4. Alternate hydraulic motor/pump.

The right hydraulic system supplies pressure for operation of the following (partial list):

1. Outboard spoilers;
2. Rudder power;
3. Wing flap inboard actuators;
4. Alternate hydraulic motor/pump; and
5. Landing gear.

Each engine-driven hydraulic pump is capable of providing 3,000 psi system pressure. The auxiliary (electric) hydraulic system pump, which is also capable of supplying the needs of the right hydraulic system (3,000) psi, is powered from the left generator bus. The alternate hydraulic motor/pump utilizes pressure from an operating hydraulic system (either) to provide pressure to the opposite unpressurized system. Identical 15 micron, non-bypassing line-type filters are installed in the engine-driven hydraulic pump pressure and case drain lines, the

auxiliary hydraulic pump pressure line, and the hydraulic system return line.

Priority valves in the pressure lines of the left and right hydraulic systems give the flight controls priority on pressure available. The valves are designed to prevent hydraulic pump output to pass through the valve unless the pressure is 2,000 psi or above. Midwest Express procedures require that all hydraulic pumps be turned on for takeoff.

The landing gear assemblies are retracted by pressure from the right hydraulic system. When retracted, the gear assemblies are fully enclosed by doors which are hydraulically and mechanically actuated during the retraction cycle. When retracted, the main gear assemblies rest on mechanically latched main gear doors. The door latches can be released hydraulically or mechanically.

Appendix H Excerpts From Engine Repair Manual Regarding 8-9 Compressor Blade Fractures

Pratt & Whitney Aircraft JTBD ENGINE MANUAL (PN 481672 - RESTRUCTURED) COMPRESSOR BLADES, STAGE 9 - INSPECTION-01

1. Task 72-36-33-22-000: Visual/Dimensional Inspection

A. Prerequisites

(1) Fluorescent penetrant inspect per Task 72-36-00-23-000, (Section 72-36-00, Inspection-01). Any crack is cause for rejection.

B. Equipment And Materials Required

Support Equipment:	PWA 11835 Template
	PWA 33375 Gage
	PWA 33314 Gage (equivalent to PWA 33375)
Consumables:	None
Expendable Parts:	None

C. Procedure

D. Unless otherwise specified, compressor blade blend limits, as specified in this manual, are evaluated from the standpoint of structural integrity only and use of substantial number of blades repaired at or near maximum limits or blades having many repaired areas may adversely affect compressor efficiency and engine performance.

Subtask 72-36-33-22-009

1. Blade fractures and airfoil cracks.
2. The following information specifically applies to engines which have been removed due to stalls, but also should be followed as a general inspection.
3. Evidence of fracture or cracking in either 8th or 9th stage blades is justification to scrap all blades of both stages.
 - a. Inspect for fractures originating in airfoil just above root platform (Figure 801). Such fractures without evidence of foreign object damage and exhibiting multiple origins on fracture surface as shown in View A in Figure 801, indicate excessive blade airfoil stress. Because of this severe stress environment and resultant loss in material strength, remaining 8th and 9th stage blades should be scrapped when this condition is observed.

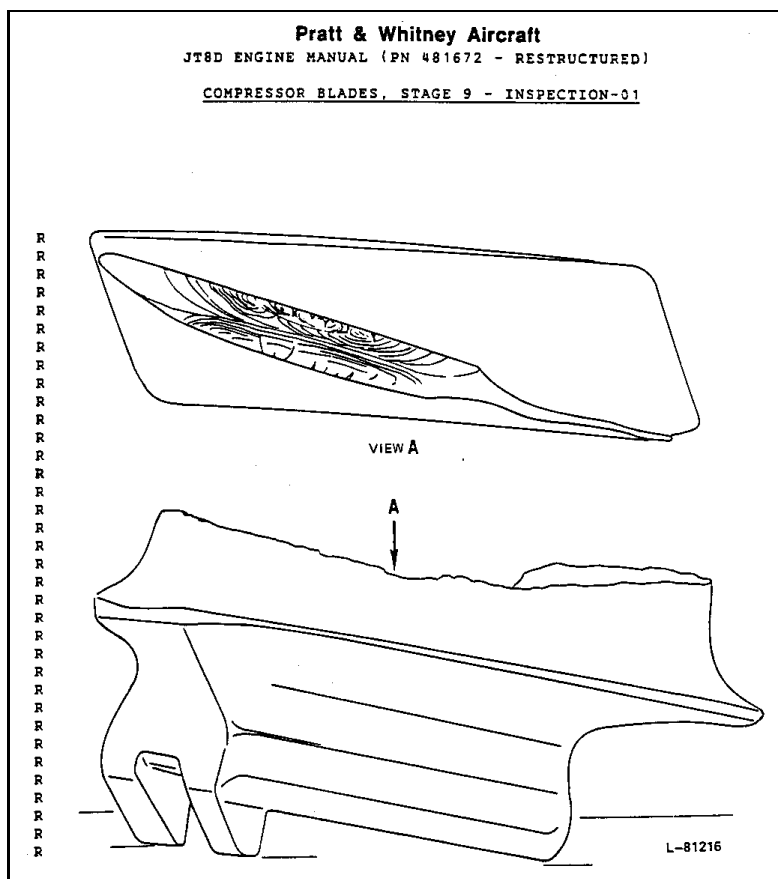

- b. Inspect blade airfoils for cracking in area just above platform. Any blade exhibiting cracking in this area also indicates excessive blade stress. See Figure 802. Remaining 8th and 9th stage blades should be scrapped regardless of whether or not they exhibit cracking.

Subtask 72-36-33-22-001

4. LIMITS APPLY TO DAMAGED AREAS AFTER BLENDING AND NOT TO MAGNITUDE OF DAMAGE MEASURED BEFORE BLENDING.
5. Repair of minor injuries to compressor blades can be made, provided injury can be removed without exceeding allowable limits. See Figure 803.
6. Nicks in leading and trailing edges become more critical, closer to blade root.
7. Any injury in inner half of airfoil should be considered for repair only after most critical inspection.
8. Blade portions, which have sustained indentations (having blade material compressed and edges raised) and injuries with small radii or ragged edges, must be removed.
9. Segregate those blades having deep nicks along leading, or trailing edge from those having minor scratches and pits.
10. Well rounded injuries to leading and trailing edges which can be seen on opposite side of blade are acceptable without rework, provided injury is in outer half of blade and indentation does not exceed 0.010 inch.
11. Total blended length on any rear compressor blade edge shall not be in excess of 1/4 of total edge length.
12. Blends on both edges must not be directly opposite and must be separated diagonally by minimum distance equal to mean chordal length of blade. See Figure 804.
13. Length of blend must be four times depth.
14. Not more than one (edge) blend per edge is permitted.
15. Blends in Area A can be considered separately and are not accountable in computing above limits.
16. All blade surfaces must be, as nearly as possible, comparable to new blade.

Appendix I Discussion of Left Engine Power Loss

The examination of the left engine revealed case and gearbox deformation and internal damage which was most predominant in the 4 o'clock position. This was consistent with the left engine having been subjected to similar impact forces as those to which the fuselage was subjected at initial ground impact. The blue paint smears, rivet marks, and red paint transfer found on the right side of the nose cowl suggested further that the engine impacted the fuselage immediately following fuselage ground impact. Seat leather and foam material, similar to that used in aircraft seat upholstery, were found jammed inside a fractured guide vane. Three adjacent guide vanes had blue paint smears, and one vane had white paint smears. The paint smears were consistent with the fuselage paint color scheme. Also, airframe insulation was found in the engine. This evidence also indicated that the engine collided with the fuselage at ground impact, probably as the fuselage was collapsing, which allowed the engine to also

impact interior cabin furnishings.

Low pressure compressor stator vanes and blades, the inlet case, and the front fan case were found between the point of airplane impact and the final resting place of the left engine, indicating that the breakup of the front section of the engine was initiated by the airplane impact. The rotating first and second stage fan blades were damaged by case deformation and frontal impact damage, indicating significant rotation at the time of the initial impact when the engine case was deformed. Evidence of rotation at impact also was indicated by extensive blade tip curling opposite the direction of rotation in both the low pressure compressor and in the high pressure compressor.

Since dirt and wood were not ingested into the engine, engine rotation apparently had slowed substantially, or stopped, before the engine came to rest in a wooded area. Impact damage from the right side of the engine at the 4 o'clock position fractured the gearbox, broke the fuel control linkages, and tore the fuel control unit from the fuel pump. Obviously, fuel to the engine was abruptly interrupted and continued engine operation was not possible even if there had not been significant internal engine damage. Extensive internal damage to blades, stators and guide vanes associated with impact and clashing between rotating parts and stator vanes in the low pressure compressor would have resulted in engine flameout and rapid engine deceleration following the initial impact of the left engine with the fuselage. The time required for such a spooldown could not be measured, but it is estimated to have occurred in fractions of a second. The Safety Board believes that sixth stage rotor blades were liberated after the initial impact and resultant clashing in the low pressure compressor.

The left engine fuel shutoff valve was cable operated. The Board does not believe its postimpact position is meaningful because its position would have changed when its cable system was subjected to impact loads.

The eighth and ninth stage high pressure compressor blades, which failed in reverse bending low cycle, high stress fatigue, had fracture characteristics which were identical to descriptions of blade fatigue fractures in the JT8D Engine Repair Manual. Pratt & Whitney advised the Safety Board that such fractures could occur during severe flexing of the blade in less than a few seconds; the higher the repeated stress, the smaller number of cycles and, hence, the shorter time required to rupture. The Safety Board accepts the theory that repeated high stress flexing at the proper frequency could cause such failures in a short time, but it does not believe that such stresses would have been repeated between the time of the initial left engine impact and the time the engine finally came to rest. The extent of case, gearbox, and internal damage which occurred at the time of the massive initial airplane fuselage impact, when transferred to the left engine, abruptly wrenched the engine free of its engine pylon and drove it through the fuselage, causing it to be deformed substantially. The frequencies and resonance associated with impact would have been rapidly diminished as the engine case was deformed and as blades and stators fractured and were distorted because of the shifting of rotors and clashing within the engine. The immediate result would have been flameout and a rapid spooldown of the engine, and not the repeated cyclic overstress which would have been required to fracture the eighth and ninth stage blades in fatigue.

In an effort to resolve the mechanism by which the blades were stressed to produce reverse bending fatigue fractures, Pratt & Whitney conducted eighth stage blade flutter demonstrations using an airstream, to excite the blade in first bending flutter. Increasing the exciting force resulted in high stress fractures in 3 to 6 seconds and, as a result of a sustained airstream, produced a resonant airfoil frequency and a flutter mode. The fracture surfaces were coarse-textured and had multiple origins on the convex and concave surfaces, similar the fractured eighth and ninth stage blades from the Midwest Express left engine. Pratt & Whitney estimated that the time to failure would have been substantially reduced, other conditions remaining the same, if centrifugal and normal aerodynamic steady stresses on the airfoil had been applied in the demonstration to more accurately duplicate the accident environment for the left engine.

Based upon the evidence and considering the results of the Pratt & Whitney research, the Safety Board believes that the eighth and ninth stage blades failed in fatigue as a result of violent compressor stalls. Further, these compressor

stalls occurred as the aircraft was falling to the ground, when the fuselage was blocking much of the airflow to the left engine inlet. If a left engine compressor stall occurred after stickshaker activation and stall of the aircraft, and precipitated blade fractures in the eighth and ninth stages of the high pressure compressor, about 5 seconds would have been available to precipitate the fractures before ground impact. The blade failures and subsequent downstream damage in the engine would have begun to generate abnormally high temperature in the aft section of the engine. Such evidence, in the form of heavy coarse metallization of a titanium based alloy, was observed on the inner surface of the outer shroud and on turbine blade airfoils. The coarseness of deposits on hot section components indicates that debris had passed through the engine while there was still airflow through the engine, a characteristic which was inconsistent with blade fractures occurring at the initial ground impact. The absence of severe damage in the turbine suggests that the left engine flight duration in a stalled condition was short. This is consistent with a compressor stall that was initiated at or after stickshaker activation.

The balled-up piece of titanium alloy, which was identified as an 8th stage blade root and was found jammed in the 11th stage stator assembly, apparently had been loose in the gas flow path for at least a few seconds to have become so misshapened. The amount of damage to this blade was inconsistent with its being liberated and balled up after ground impact. An airfoil section, which was identified as part of a high pressure compressor blade, was trapped between the eighth stage stator support rail and a slightly buckled section of the rear skirt in a manner which indicated that it had been liberated from the compressor and was in place when the rear skirt was deformed by ground impact. This airfoil and the balled-up blade both suggested that the eighth and, possibly, the ninth stage blades fractured in flight.

Many high energy outward perforations were observed in the intermediate case rear inner duct in the plane of rotation of the eighth and ninth stage rotors. This damage and damage to the eighth and ninth stage stators, which had mechanically impacted the shroud, indicated that some blades from those rotors had become detached while rotating at high energy and not after ground impact.

Sharp imprints of rotor blades were observed on the trailing edges of the fifth, seventh, and eighth stage stators, indicating the rotor blades had clashed with the stators. Such damage is typical of compressor stalls where rotor blades move forward rapidly, sometimes striking stator vanes. The Safety Board believes that the occurrence of compressor stalls in the last seconds of the flight as the airplane fell to the ground would account for the clashing damage, the fatigue fractures of the eighth and ninth stage blades, the balled-up eighth stage blade root, the trapped airfoil, and perforations in the intermediate case. The Board does not attribute the compressor stall to a malfunction of the engine, but to the unusual attitude of the aircraft and resultant obstruction of airflow into the left engine in the last seconds of flight.

A compressor stall or series of stalls occurring at or after stickshaker activation would not explain the reduction of left engine power which was indicated by the sound spectrum examination of CVR noises which began about 1.5 seconds after the right engine failed. The sound spectrum during the period following failure of the right engine indicated a fairly slow and erratic reduction of N1 and N2, and thus, power on the left engine. However, the erratic relationship between N1 and N2 is not conducive to detailed analysis because of the short time interval and an insufficient number of data points from which to analyze engine performance. Pratt & Whitney testimony indicated that the reduction of N1 and N2, which was documented before stickshaker, was not typical of compressor stall.

Other possible explanations for the reduction in left engine power include manual throttle manipulation by the flightcrew or mechanical stress in the engine (for an undetermined reason). The Safety Board cannot conclusively eliminate either possibility. Thus, the cause of the initial left engine power loss could not be determined. However, the Board believes that, regardless of the reason(s) for the initial power loss and the compressor stall-induced blade failures, factors related to the left engine did not contribute to the loss of control of the airplane.

¹All times herein are central daylight, based upon the 24-hour clock.

²Set to takeoff safety speed (V2) per Midwest Express procedures.

³Standard briefing, as defined by the Midwest Express chief pilot, is a phrase which indicates it is a standard day and normal procedures are to be utilized. The chief pilot said that discussion of the eventualities and responsibilities of takeoff emergencies were not required to be discussed before each takeoff. Standard briefings are routinely used when pilots are familiar with one another and departure conditions are routine.

⁴Midwest Express callsign.

⁵The loud noise was described in the CVR transcript as a "clunk" sound.

⁶The # symbol was used in the CVR transcript to describe a nonpertinent word which was not transcribed.

⁸"Unspooling" refers to the rpm of the high pressure compressor (N2) dropping to idle rpm.

⁹Blending is a term used to describe machining to remove or smooth a damaged area.

¹⁰The minimum control speed with the critical engine inoperative.

¹¹A gust recorder (anemometer) records wind velocity only, and not the direction from which the wind is blowing.

¹²Automated Radar Terminal System. The suffix, III, denotes a specific system capability.

¹³Airport Surveillance Radar.

¹⁴That component of inertial acceleration which is perpendicular to the airplane's lateral and longitudinal axes.

¹⁵Characteristic blade passing frequency is assumed to result from the fan blades causing pressure pulses in the air during rotation.

¹⁶Yaw is the rotational movement about the airplane vertical axis from a fixed reference point. Sideslip is the sideward movement of the airplane, where the relative wind is offset to the left or right of the longitudinal axis of the airplane.

¹⁷At these speeds and altitudes, KIAS and KEAS are generally considered to be the same, if there are no instrument errors or static source errors. A static source error would create a difference between KEAS and KIAS.

¹⁸Vortilon (vortex generating pylons) are installed on the wing lower surfaces to provide airflow control.

¹⁹McCarthy, D., "Types of Rotor Failure and Characteristics of Fragments," An Assessment of Technology for Turbojet Engine Rotor Failures (Massachusetts Institute of Technology, March 29-31, 1977).

²⁰A tumbling rectangular object presents an average frontal area of 0.635 times (the side 1 plus side 2 area).

²¹Cycles were defined as a flight, including one takeoff and landing.

²²McDonnell Douglas DC-9 Service bulletin 27-209, issued May 29, 1981, and Airworthiness Directive (AD) 82-04-02, effective March 21, 1982, were issued to require periodic inspections of the magnesium alloy rudder pedal support arms to detect possible fatigue cracking that had resulted in past failures of rudder pedal support arms during ground operations. Maintenance records for N100ME revealed that the inspection specified by the AD had been accomplished in August 1985 and that no cracks were detected.

²³"Silent cockpit" is a term coined at the Safety Board's public hearing to describe a period during which Midwest Express pilots were taught that it was unnecessary to verbalize callouts or to identify the nature of emergency or abnormal situations which might occur.

²⁴MGLO is the minimum altitude at which the aircraft should be leveled off to complete the engine failure transition and to assure clearance of obstructions in the takeoff path. Standard MGLO for the DC-9 (Midwest Express) is 800 feet.

²⁵Caro, P.W. "The Relationship Between Flight Simulator Motion and Training Requirements", *Human Factors*, 1979, 21, 493-501.

²⁶Lee, Alfred T. and Bussolari, Steven R., "Flight Simulator Requirements for Airline Transport Pilot Training: An Evaluation of Motion System Design Alternatives," 1985, Proceedings of the IEE Second International Conference on Simulators, University of Warwick, U.K.

²⁷Shop reviews are inspections of JT8D or JT9D engine repair facilities, including disassembly, assembly, repair, inspection, and test operations with the objective of providing recommendations which might result in reduction of maintenance costs and improved reliability of engines processed through the facility. Pratt & Whitney provides this service, with confidentiality, at no cost to the repair facility.

²⁸Wierwille, W.W., Cassali, J.G., and Repa, B.S., Driver steering reaction time to abrupt-onset crosswinds, as measured in a moving base driving simulator. *Human Factors*, 1983.

²⁹Aircraft Accident Report--"Galaxy Airlines, Inc., Lockheed Electra L-188C, N5532, Reno, Nevada, January 21, 1985" (NTSB/AAR-86/01).

³⁰Remainder of procedure not relevant to accident flight.